

THE

DUPLICATE

# cherokee **ARROW**

PILOT'S OPERATING MANUAL

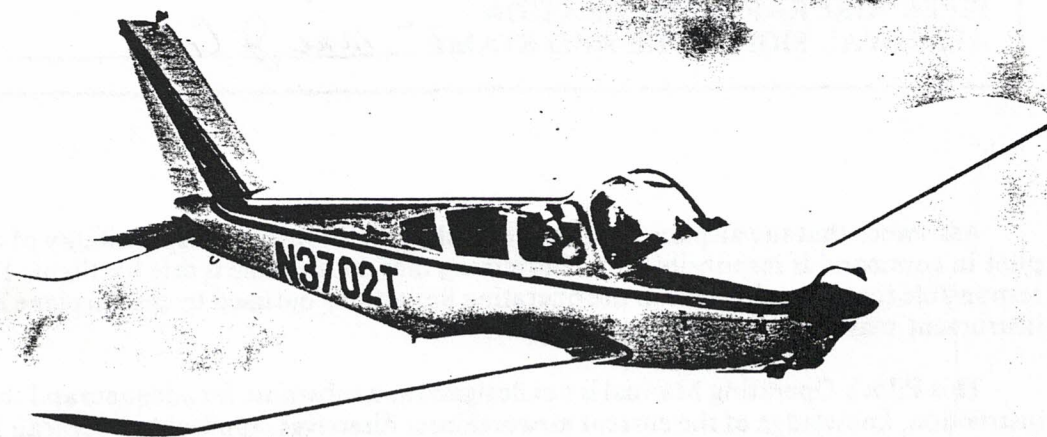

BY



This manual is incomplete without an APPROPRIATE FAA APPROVED AIRPLANE FLIGHT MANUAL and an APPROPRIATE WEIGHT AND BALANCE REPORT.

DUPLICATE

**WARNING**

EXTREME CARE MUST BE EXERCISED TO LIMIT THE USE OF THIS MANUAL TO APPLICABLE AIRCRAFT. THIS MANUAL REVISED AS INDICATED BELOW OR SUBSEQUENTLY REVISED IS VALID FOR USE WITH THE AIRPLANE IDENTIFIED BELOW WHEN APPROVED BY PIPER AIRCRAFT CORPORATION. SUBSEQUENT REVISIONS SUPPLIED BY PIPER AIRCRAFT CORPORATION MUST BE PROPERLY INSERTED.

MODEL PA-28R-200

AIRCRAFT SERIAL NO. 28R-7635337 REGISTRATION NO. N6828J

PILOT'S OPERATING MANUAL, PART NUMBER 761 578 REVISION 12

PIPER AIRCRAFT CORPORATION

APPROVAL SIGNATURE AND STAMP

*Gene J. Conn*



Assurance that the airplane is in an airworthy condition is the responsibility of the owner. The pilot in command is responsible for determining that the airplane is safe for flight. The pilot is also responsible for remaining within the operating limitations outlined by the Airplane Flight Manual, instrument markings, and placards.

This Pilot's Operating Manual is not designed as a substitute for adequate and competent flight instruction, knowledge of the current airworthiness directives, applicable federal air regulations, or advisory circulars. It is not intended to be a guide for basic flight instruction or a training manual for transition from single to multi-engine flying.

If an inconsistency of information exists between the Pilot's Operating Manual and the Airplane Flight Manual approved by the FAA, the Airplane Flight Manual shall be the authority.

A complete or partial replacement of this manual, Part No. 761 578, may be obtained only from Piper Customer Services.

Published by  
PUBLICATIONS DEPARTMENT  
Piper Aircraft Corporation

761 578

Issued: July 1973

## APPLICABILITY

This manual is applicable to Piper Model PA-28R-200 aircraft having serial numbers commencing with 28R-7435001 through 28R-7635545. Contact Piper Customer Services for specific information on the application of this manual.

## REVISIONS

The information compiled in the Pilot's Operating Manual will be kept current by revisions distributed to the airplane owners.

Revision material will consist of information necessary to update the text of the present manual and/or to add information to cover added airplane equipment.

### I. Revisions

Revisions will be distributed whenever necessary as complete page replacements or additions and shall be inserted into the manual in accordance with the instructions given below:

1. Revision pages will replace only pages with the same page number.
2. Insert all additional pages in proper numerical order within each section.
3. Page numbers followed by a small letter shall be inserted in direct sequence with the same common numbered page.

### II. Identification of Revised Material

Revised text and illustrations shall be indicated by a black vertical line along the left hand margin of the page, opposite revised, added or deleted material. A line opposite the page number or section title and printing date, will indicate that the text or illustration was unchanged but material was relocated to a different page or that an entire page was added.

Black lines will indicate only current revisions with changes and additions to or deletions of existing text and illustrations. Changes in capitalization, spelling, punctuation or the physical location of material on a page will not be identified by symbols.

### III. Original Pages Issued

The original pages issued for this manual prior to revision are given below:

1-1 through 1-3, 2-1 through 2-24, 3-1 through 3-10, 4-1 through 4-8, 5-1 through 5-32, 7-1 through 7-10, 8-1 through 8-2, 9-1 through 9-10, 10-1 through 10-15.

## PILOT'S OPERATING MANUAL LOG OF REVISIONS

Current Revisions to the PA-28R-200 Arrow II Pilot's Operating Manual, 761 578, issued July 13, 1973.

Revision	Revised Pages	Description	Date
Rev. 1 - 761 578 (PR731029)	W/B	Added Rev. 1 to Report: VB-549.	Oct. 29, 1973
Rev. 2 - 761 578 (PR740325)	ii iii  A F/M W/B	Added PAC Approval Form. Added Applicability and Item III. Original Pages Issued. Added Rev. 1 to Report: VB-560. Added Rev. 2 to Report: VB-549. (NOTE: AIRCRAFT DELIVERED WITH MANUALS PRIOR TO THIS REVISION DO NOT REQUIRE THIS REVISION.)	March 25, 1974
Rev. 3 - 761 578 (PR740618)	2-2 2-4  2-11  2-12 2-12a  2-12b 2-14  2-15  2-16  2-20 A F/M 4-8  W/B 7-i  7-4  7-5	Added Mixture Control Lock and Footnote. Added Mixture Control Lock to Throttle Quadrant Illustration. Added Annunciator Panel and Footnote; added Landing Gear Light Dimming Warning. Revised Alternator and Starter Schematic. Added Alternator and Starter Schematic for 1975 Models. Added Intentionally Left Blank Page. Added Annunciator Panel and Footnote to Vacuum System Description. Added Annunciator Panel and Footnote to Instrument Panel Description. Added Annunciator Panel and Mixture Control Lock to Instrument Panel Illustration. Added Rear Seat Removal Instructions. Added Revision 2 to Report: VB-560. Revised Alternator Failure Emergency Procedures. Added Revision 3 to Report: VB-549. Revised Operating Instructions Index; added Airspeed Data. Revised Air Conditioner Ground Check; added Annunciator Panel Check and Footnote; relocated info. Added info from Page 7-4; relocated Cruising info.	June 18, 1974

**PILOT'S OPERATING MANUAL LOG OF REVISIONS (cont)**

Revision	Revised Pages	Description	Date
Rev. 3 (cont)	7-6	Added Cruising info; added Mixture Control Lock and Footnote; relocated Approach and Landing info.	
	7-7	Added Approach and Landing info; added Mixture Control Lock and Footnote; relocated Moorings and Weight and Balance info.	
	7-8	Added Airspeed Data; added Moorings, and Weight and Balance info; relocated ELT info.	
	7-9	Added info from Page 7-8; relocated Air Conditioning info.	
	7-10	Added Air Conditioning info; relocated info.	
	7-11	Added page; added relocated info.	
	8-1	Added Annunciator Panel to Item 11; moved Item 13 to Page 8-2.	
	8-2	Added Item 13 from Page 8-1.	
	9-i	Revised Performance Charts Index.	
	9-2	Revised Takeoff Chart.	
	9-3	Revised Climb Chart.	
	9-4	Revised Airspeed Chart.	
	9-5	Revised Range Chart.	
	9-8	Revised Glide Chart.	
	9-9	Revised Landing Chart.	
Rev. 4 - 761 578 (PR750128)	2-6	Added gear warning info.	Jan. 28, 1975
	2-21	Revised Stall Warning info.	
Rev. 5 - 761 578 (PR750627)	1-2	Revised Empty Weight and Useful Load.	June 27, 1975
	2-1	Revised Empennage info. (Airframe).	
	2-6	Revised Gear Warning info.	
	2-13	Added C/B door callout to illustration.	
	2-16	Added Engine Hour Meter; revised callouts.	
	2-20	Revised seat description and deleted seat illustration.	
	2-21	Revised Stall Warning info.	
	2-22	Deleted Air Conditioning illustrations.	
	2-23	Deleted Air Conditioning illustrations; added info from page 2-24.	
	2-24	Relocated info to page 2-23.	
	A F/M	Added Rev. 3 to Report: VB-560.	

## PILOT'S OPERATING MANUAL LOG OF REVISIONS (cont)

Revision	Revised Pages	Description	Date
Rev. 5 (cont)	4-4	Revised Power Off Landing info; added new item 1. and revised existing item nos. under Gear Down Landing; revised Gear Down Landing Note.	
	W/B	Added Rev. 4 to Report: VB-549.	
	7-4	Added new item 11. and revised existing item nos. under Takeoff.	
	7-8	Revised ELT info.	
	7-9	Added revised ELT info.	
	8-2	Revised item 14. (Fuel Warning Placard) and added new item 17.	
Rev. 6 - 761 578 (PR751208)	2-3	Revised Landing Gear info.	Dec. 8, 1975
	A F/M	Added Rev. 4 to Report: VB-560.	
	W/B	Added Rev. 5 to Report: VB-549.	
	7-9	Revised ELT remote switch info; relocated material to page 7-10.	
	7-10	Added material relocated from page 7-9; relocated material to page 7-11.	
	7-11	Added material relocated from page 7-10.	
Rev. 7 - 761 578 (PR760712)	8-2	Revised item 14 (Fuel Warning).	July 22, 1976
	W/B	Added Rev. 6 to Report: VB-549.	
Rev. 8 - 761 578 (PR770228)	7-10	Revised pilot's remote switch description; revised existing data.	Feb. 28, 1977
	1-2	Added Lycoming IO-360-C1C6 Power Plant and McCauley Propeller.	
	2-2	Added IO-360-C1C6 Engine and footnotes; revised prop. description.	
	2-20	Revised seat retainer description.	
	A F/M	Added Rev. 5 to Report: VB-560.	
Rev. 9 - 761 578 (PR790413)	W/B	Added Rev. 7 to Report: VB-549.	April 13, 1979
	7-10	Revised ELT Note.	
	2-11	Removed Note; added Warning.	
	2-18	Added Caution.	
	W/B	Added Rev. 8 to Report: VB-549.	
	7-8	Revised ELT info.	
	7-9	Revised ELT info.	
	10-8	Added Caution; relocated info. to pg. 10-9.	

## PILOT'S OPERATING MANUAL LOG OF REVISIONS (cont)

Revision	Revised Pages	Description	Date
Rev. 9 (cont)	10-9 10-11	Added info. from page 10-8. Revised Service Bulletin info.	Feb. 29, 1984
Rev. 10 - 761 578 (PR840229)	iii	Added including serial number.	
	1-2	Revised fuel and oil info.	
	2-21	Revised para.	
	AFM	Added Rev. 6 to Report: VB-560.	
	W/B	Added Rev. 9 to Report: VB-549.	
	9-i	Added Warning.	
	10-7	Added info., and fuel grade chart, moved info. to page 10-8.	
	10-8	Relocated info. from pg. 10-7, moved info. to page 10-9.	
	10-9	Relocated info. from page 10-8.	
	10-11	Revised para.	
10-12	Revised preventive maintenance para., relocated info. from page 10-13.		
10-13	Moved info. to page 10-12.		
Rev. 11 - 761 578 (PR870131)	2-3	Revised Landing Gear. Relocated Warning	Jan. 31, 1987
	2-4	Revised Throttle Quadrant and Console figures.	
	2-5	Revised Schematic.	
	2-6	Revised para. Added info.	
	2-16	Revised Instrument Panel fig.	
	AFM	Added Rev. 7 to Report: VB-560.	
	4-2	Revised Engine Power Loss During Take off para.	
	4-3	Revised Engine Power Loss During Takeoff.	
	4-4	Revised Power Off Landing, Gear Down Landing, and Gear Up Landing paras. Moved info. from page 4-5.	
	4-5	Revised Emergency Gear Extension para. Moved info. to page 4-4.	
	4-6	Revised Note.	
	7-5	Revised footnote.	
	8-1	Revised item 12.	
	9-8	Revised Note.	
	10-14	Added Note.	
10-15	Added note reference.		

PILOT'S OPERATING MANUAL LOG OF REVISIONS (cont)

Revision	Revised Pages	Description	Date
Rev. 12 - 761 578 (PR900730)	1-2	Revised Oil info. Moved Dimensions and Landing Gear to page 1-4.	July 30, 1990
	1-4	Added page. Relocated Dimensions and Landing Gear from page 1-2.	
	10-i	Revised Table of Contents.	
	10-7	Revised Oil Requirements. Moved info. to page 10-8.	
	10-8	Relocated info. from page 10-7. Moved Tire Inflation and Battery Service info. to page 10-9.	
	10-9	Relocated Tire inflation and Battery Service info. from page 10-8.	
	10-11	Revised Facts You Should Know.	
	10-12	Revised Preventive Maintenance.	
	10-13	Revised Required Service and Inspection Periods.	

# **TABLE OF CONTENTS**

**GENERAL SPECIFICATIONS**

**DESCRIPTION-AIRPLANE AND SYSTEMS**

**AIRPLANE FLIGHT MANUAL F.A.A. APPROVED**

**EMERGENCY PROCEDURES F.A.A. APPROVED**

**EMERGENCY PROCEDURES**

**WEIGHT AND BALANCE**

**LOADING INSTRUCTIONS**

**OPERATING INSTRUCTIONS**

**OPERATING TIPS**

**PERFORMANCE CHARTS**

**HANDLING AND SERVICING**



# GENERAL SPECIFICATIONS

Performance .....	1-1
Weights .....	1-2
Power Plant .....	1-2
Fuel and Oil .....	1-2
Baggage .....	1-2
Dimensions .....	1-2
Landing Gear .....	1-2

BLANK PAGE

---

**SPECIFICATIONS**
**PERFORMANCE**

Published figures are for standard airplanes flown at gross weight under standard conditions at sea level, unless otherwise stated. Performance for a specific airplane may vary from published figures depending upon the equipment installed, the condition of the engine, airplane and equipment, atmospheric conditions and piloting technique. Each performance figure below is subject to the same conditions as on the corresponding performance chart from which it is taken in the Performance Charts Section.

Takeoff Run (ft)	1025
Takeoff Run (Short field effort, 25° flaps) (ft)	770
Takeoff Distance Over 50-ft Obstacle (ft)	1800
Takeoff Distance Over 50-ft Obstacle (Short field effort, 25° flaps) (ft)	1600
Best Rate of Climb (mph)	95 (100*)
Rate of Climb (gear retracted) (ft per min)	900
Best Angle of Climb (mph)	85 (96*)
Service Ceiling (ft)	15,000
Absolute Ceiling (ft)	17,000
Max Speed (mph)	175
Optimum Cruising Speed (75% power, optimum altitude, 6600 ft) (mph)	165
Cruise Speed at best power mixture (mph)	
65% power, 9,750 ft	159
55% power, 13,000 ft	150
Range at best power mixture (mi)**	
75% power, 6600 ft	665
65% power, 9750 ft	715
55% power, 13,000 ft	765
Cruise Speed at best economy mixture (mph)	
75% power, 6600 ft	156
65% power, 9700 ft	148
55% power, 13,100 ft	141
Range at best economy mixture (mi)**	
75% power, 6600 ft	740
65% power, 9700 ft	785
55% power, 13,100 ft	850
Stalling Speed (flaps and gear down) (CAS) (mph)	64
Stalling Speed (flaps and gear up) (CAS) (mph)	71
Landing Roll (flaps down) (ft)	780
Landing Roll Over 50-ft Obstacle (ft)	1380

\*Gear retracted

\*\*No reserve

## ARROW II

### WEIGHTS

Gross Weight (lbs)	2650
Standard Empty Weight (lbs)	1531
Maximum Useful Load (obs)	1198

### POWER PLANT

	S/N 28R-7435001 thru 28R-7635516	S/N 7635517 & Up
Engine (Lycoming)	IO-360-C1C	IO-360-C1C6
Propeller	Hartzell HC-C2YK-1( )/7666A-2 or HC-C2YK-1( )F/7666A-2	McCauley B2D34C213/90DHA-16
Rated Horsepower	200	200
Rated Speed (rpm)	2700	2700
Bore (in )	5.125	5.125
Stroke (in.)	4.375	4.375
Displacement (cu. in.)	361.0	361.0
Compression Ratio	8.7:1	8.7:1
Dry Weight (lbs)	326	333

### FUEL (AVGAS ONLY)

Usable Fuel Capacity (U.S. gal.)	48
Fuel, Aviation Grade (min octane)	100/130

### OIL

Oil Capacity (qts)	8	
Oil Specification	Refer to latest issue of Lycoming Instruction No. 1014.	
Oil Viscosity per Average Ambient Temp. for Starting		
	MIL-L-6082B	MIL-L-22851
	Mineral	Ashless Dispersant
	SAE Grade	SAE Grades
All Temperatures	—	15W-50 or 20W-50
Above 80°F	60	60
Above 60°F	50	40 or 50
30°F to 90°F	40	40
0°F to 70°F	30	30, 40 or 20W-40
0°F to 90°F	20W-50	20W-50 or 15W-50
Below 10°F	20	30 or 20W-30

When operating temperatures overlap indicated ranges, use the lighter grade oil.

### BAGGAGE

Maximum Baggage (lbs)	200
Baggage Space (cu ft)	22
Baggage Door Size (in)	20 x 22

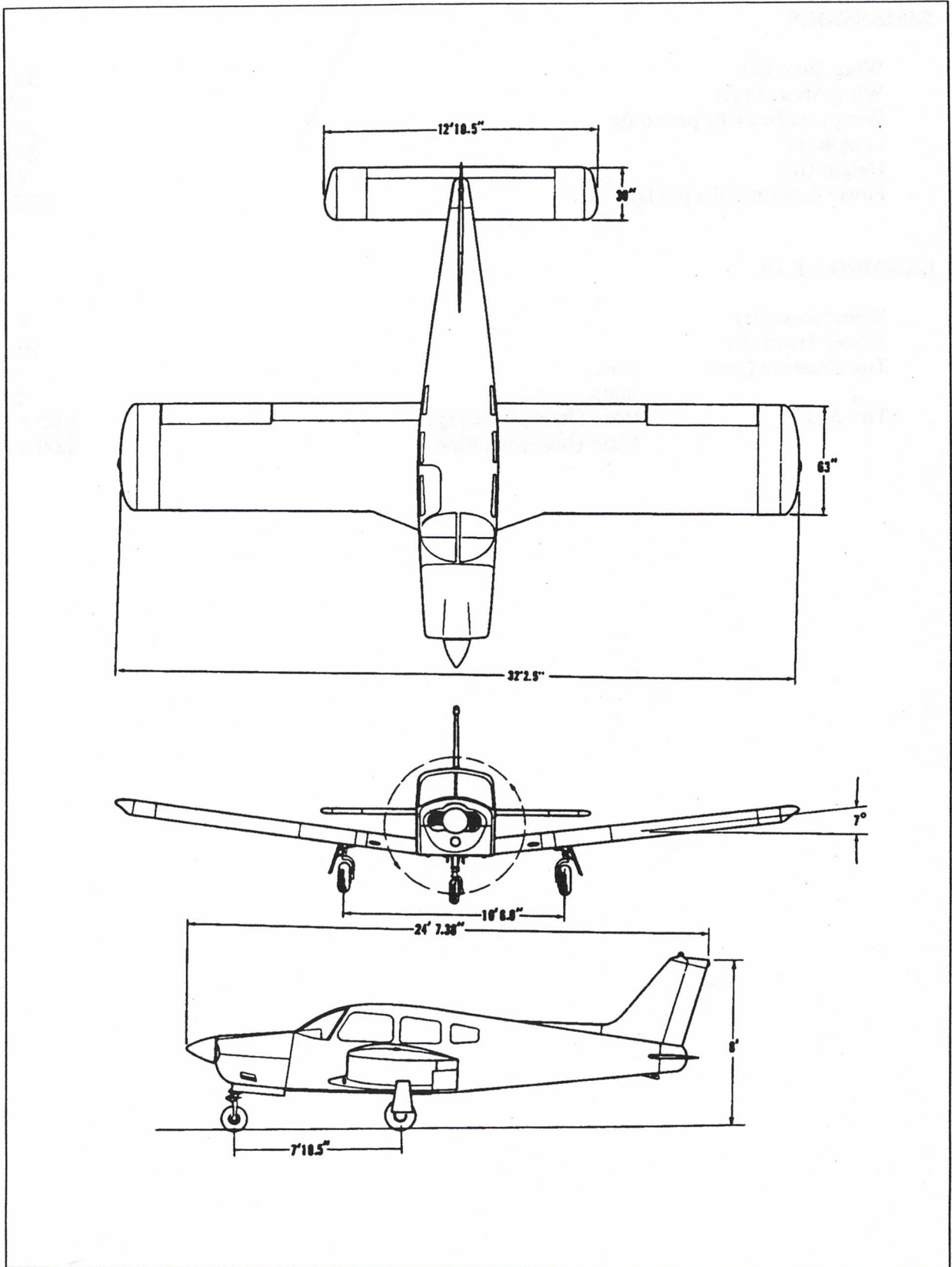

GENERAL SPECIFICATIONS  
ISSUED: JULY 13, 1973

# ARROW II

## DIMENSIONS

Wing Span (ft)	32.2
Wing Area (sq ft)	170
Wing Loading (lbs per sq ft)	15.6
Length (ft)	24.6
Height (ft)	8.0
Power Loading (lbs per hp)	13.25

## LANDING GEAR

Wheel Base (ft)	7.8	
Wheel Tread (ft)	10.5	
Tire Pressure (psi)	Nose	30
	Main	27
Tire Size	Nose (four-ply rating)	5.00 x 5
	Main (four-ply rating)	6.00 x 6

# DESCRIPTION

## AIRPLANE AND SYSTEMS

The Airplane .....	2-1
Airframe.....	2-1
Engine and Propeller .....	2-2
Landing Gear .....	2-3
Flight Controls .....	2-8
Fuel System .....	2-9
Electrical System .....	2-11
Vacuum System .....	2-14
Instrument Panel .....	2-15
Pitot-Static System .....	2-15
Heating, Ventilating and Defrosting System .....	2-18
Cabin Features .....	2-20
Baggage Area .....	2-21
Stall Warning .....	2-21
Finish .....	2-21
Air Conditioning.....	2-21
Piper External Power .....	2-24

BLANK PAGE

DESCRIPTION

APPLIANCE AND SYSTEMS

1-1	...	...
1-2	...	...
1-3	...	...
1-4	...	...
1-5	...	...
1-6	...	...
1-7	...	...
1-8	...	...
1-9	...	...
1-10	...	...
1-11	...	...
1-12	...	...
1-13	...	...
1-14	...	...
1-15	...	...
1-16	...	...
1-17	...	...
1-18	...	...
1-19	...	...
1-20	...	...
1-21	...	...
1-22	...	...
1-23	...	...
1-24	...	...

---

## DESCRIPTION

### AIRPLANE AND SYSTEMS

#### THE AIRPLANE

The Cherokee Arrow II is a single-engine, retractable landing gear, all metal aircraft. Increased fuselage length has enhanced the comfort in the rear seats. A large cabin door allows composed entry and exit of the spacious interior. Four individual seats allow individual comfort for extended cross-country flights. Sound proofing has been built into the aircraft to reduce fatigue and permit restful conversation. Simplicity of operation was designed into the aircraft to allow the aircraft to operate in VFR or IFR conditions with unhurried en route planning.

#### AIRFRAME

Aluminum alloy construction has been used throughout for the primary structure except for the steel tube engine mount, steel landing gear struts and isolated areas. Fiberglass and thermoplastic are used extensively for wing tip, engine cowling and non-structure components. The airframe has been designed to a positive limit load factor of 3.8.

The **fuselage** is a conventional semi-monocoque structure. External stringers on the bottom of the fuselage extend the length of the cabin area, and are used to maximize cabin room. On the right side of the aircraft are a large cabin door and a large baggage compartment door. Maintenance has been reduced to a minimum with advanced fuselage design.

The **wing** is of conventional design incorporating a laminar flow NACA 65<sub>2</sub>-415 airfoil section. This allows for locating the main spar 40% aft of the leading edge, an arrangement which benefits the structure in two ways.

1. It provides unobstructed cabin space for the rear passengers.
2. It allows for a lighter wing structure to improve the useful load of the aircraft.

The wing also incorporates a rear spar and front stub spar. The main spar carries the bending loads and the rear and stub spars carry torsional loads. The main spars are bolted into a spar carry through at both sides of the fuselage. The rear and stub spars are bolted to attachments at each side of the fuselage.

The **ailerons** are of modern metal construction incorporating a balance weight on the outboard end of each aileron, and are controlled by a right or left rotation of the control wheel.

The **flaps** are also of metal construction. When the flaps are in the retracted position, the right flap acts as a step. The flap control is located between the front seats.

The **empennage** consists of a vertical stabilizer, a rudder and a horizontal stabilator. The empennage construction is of a modern lightweight design.

## ARROW II

---

### ENGINE AND PROPELLER

The Cherokee Arrow II incorporates a Lycoming IO-360-C1C\*\* or IO-360-C1C6\*\*\* four-cylinder, direct drive, horizontally opposed fuel injected engine rated at 200 horsepower at 2700 RPM. It is furnished with a starter, 60 ampere 14-volt alternator, shielded ignition, vacuum pump drive, fuel pump, propeller governor and a dry automotive type induction air filter. A recommended overhaul period of 1400 hours is based on Lycoming service experience. Operation beyond the recommended time is the decision of the operator. Since Lycoming from time to time revises the recommended overhaul period, the owner should check the latest Lycoming Service Instruction at his Piper dealer for the latest recommended overhaul period and for any additional information.

The aircraft is equipped with a constant speed, controllable pitch propeller. The propeller control is located on the power quadrant between the throttle and mixture controls. A mixture control lock\* is provided to prevent activation of the mixture control instead of the pitch control.

The **exhaust system** is a crossover type, which reduces back pressure and improves performance. It is constructed entirely of stainless steel and is equipped with dual mufflers. Cabin heat and windshield defrosting are provided by a heater shroud around the muffler.

An oil cooler is located on the forward lower right side of the firewall, with the air inlet for the cooler located on the right side of the bottom cowling. A winterization plate is provided to restrict air during winter operation. (See Winterization in Handling and Servicing.)

The **induction system** incorporates a Bendix RSA-5AD1 type fuel injector. The injector is based on the principle of differential pressure, which balances air pressure against fuel pressure. The regulated fuel pressure established by the servo valve when applied across a fuel control (jetting system) makes the fuel flow proportional to airflow. Fuel pressure regulation by the servo valve causes a minimal drop in fuel pressure throughout the metering system. Metering pressure is maintained above most vapor forming conditions while fuel inlet pressure is low enough to allow use of a diaphragm pump. The servo system feature also checks vapor lock and associated starting problems.

The servo regulation meters fuel flow proportionally with airflow and maintains the mixture as manually set for all engine speeds. The fuel flow divider receives metered fuel and distributes fuel to each cylinder fuel nozzle. The fuel flow portion of the manifold fuel flow gauge is connected to the flow divider and monitors fuel pressure. This instrument converts fuel pressure to an indication of fuel flow in gallons per hour and percentage of rated horsepower.

The alternate air source of the induction system contains a door that functions automatically or manually. If the primary source is obstructed, the door will open automatically. It may be opened manually by moving the selector on the right side of the quadrant. The primary source should always be used for take-off.

The pilot should read and follow the procedures recommended in the Lycoming Operator's Manual for this engine, in order to obtain maximum engine efficiency and time between engine overhauls.

\* Serial nos. 28R-7535001 and up

\*\* Serial nos. 28R-7435001 through 28R-7635516

\*\*\* Serial nos. 28R-7635517 and up

---

## LANDING GEAR

The Cherokee Arrow II is equipped with a retractable tricycle landing gear, which is hydraulically actuated by an electrically powered reversible pump. The pump is controlled by a selector switch of the instrument panel to the left of the control quadrant. The landing gear is retracted or extended in about seven seconds.

### WARNING

Avoid ejecting objects out of the pilot storm window which could possibly enter or obstruct the holes in the mast.

Some aircraft also incorporate a pressure sensing device in the system which lowers the gear regardless of gear selector position, depending upon airspeed and engine power (propeller slipstream). Gear extension is designed to occur, even if the selector is in the up position, at airspeeds below approximately 105 mph with power off. The extension speeds will vary from approximately 85 mph to approximately 105 mph depending on power settings and altitude. The device also prevents the gear from retracting at airspeeds below approximately 85 mph with full power, though the selector switch may be in the up position. This speed increases with reduced power and/or increased altitude. Manual override of the device is provided by an emergency gear lever located between the front seats to the left of the flap handle. The sensing device operation is controlled by differential air pressure across a flexible diaphragm which is mechanically linked to a hydraulic valve and an electrical switch which actuates the pump motor. A high pressure and static air source for actuating the diaphragm is provided in a mast mounted on the left side of the fuselage above the wing. Any obstruction of the holes in this mast will cause the gear to extend. An optional heated mast is available to alleviate obstruction in icing conditions. The optional heated mast is turned on whenever the PITOT HEAT is turned on.

The emergency gear lever, when held in the raised position, can be used to override the system, and gear position is then controlled by the selector switch regardless of airspeed/power combinations. The emergency gear lever is provided with a latching device which may be used to lock the override lever in the up position. The latch is located on the left side panel of the console below the level of the manual override lever. To lock the override lever in the up position, raise the override lever to the full up position and push in the latch. A yellow warning light located below the gear selector switch flashes to warn the pilot that the automatic gear lowering system is disabled. The latch is spring loaded to the off position to aid disengagement. To disengage the latch raise the override lever and release. The lever will return to its normal position and the yellow flashing light will extinguish. The lever must also be latched in the raised (up) position when gear-up stalls are practiced.

The emergency gear lever, when used for emergency extension of the gear, manually releases hydraulic pressure to permit the gear to free-fall with spring assistance on the nose gear. The lever must be held in the downward position for emergency extension.

Gear down and locked positions are indicated by three green lights located below the selector, and a yellow light for in-transit positions is located at the top of the panel. An all lights out condition indicates the gear is up. The landing gear should not be retracted above a speed of 125 mph and should not be extended above a speed of 150 mph.

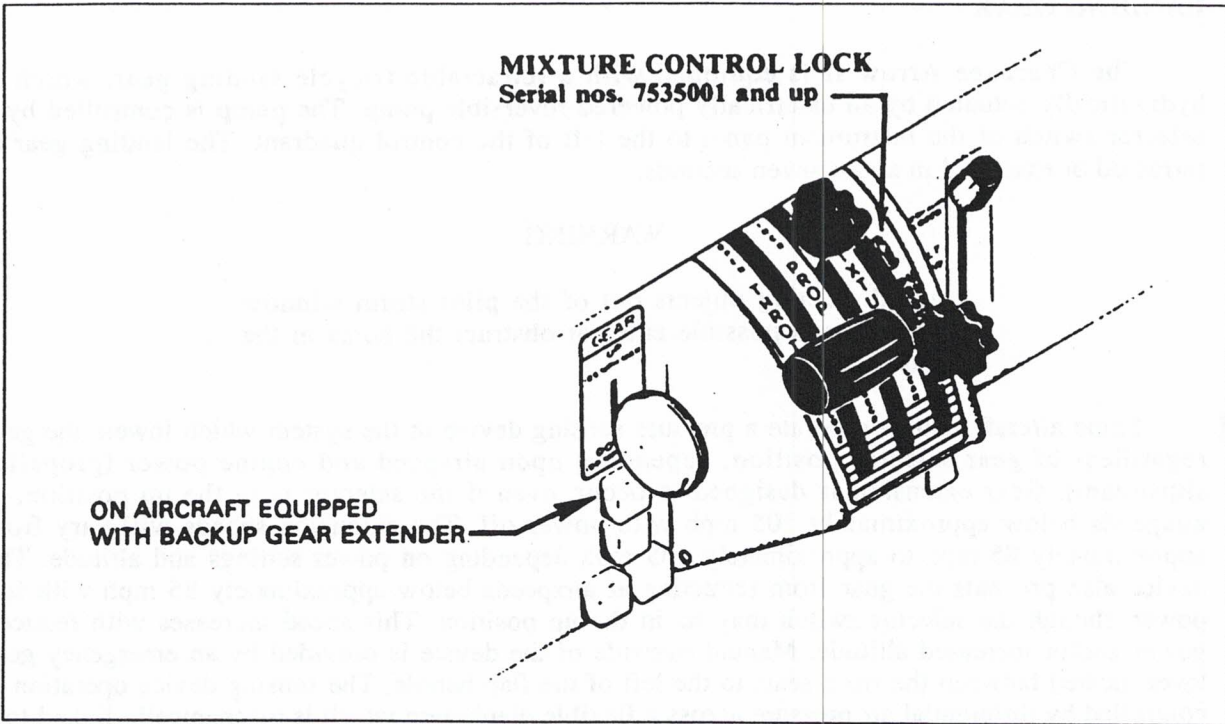

Throttle Quadrant

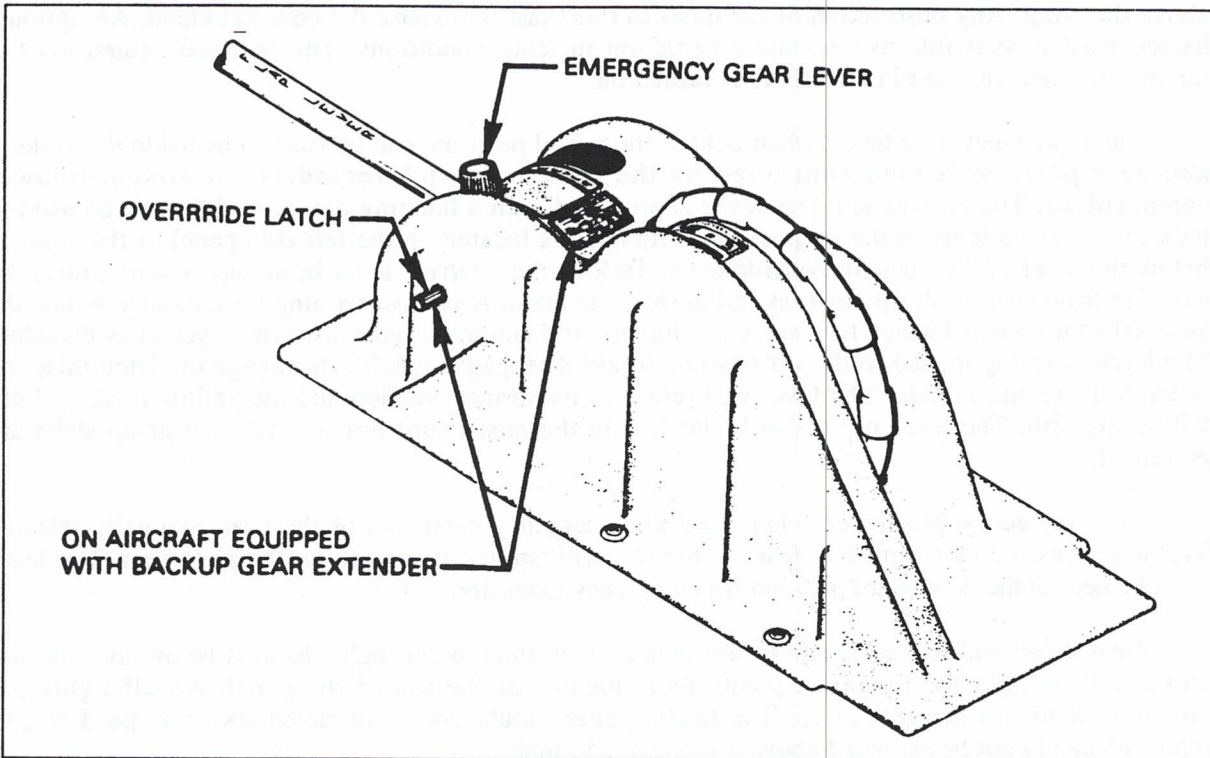

Console

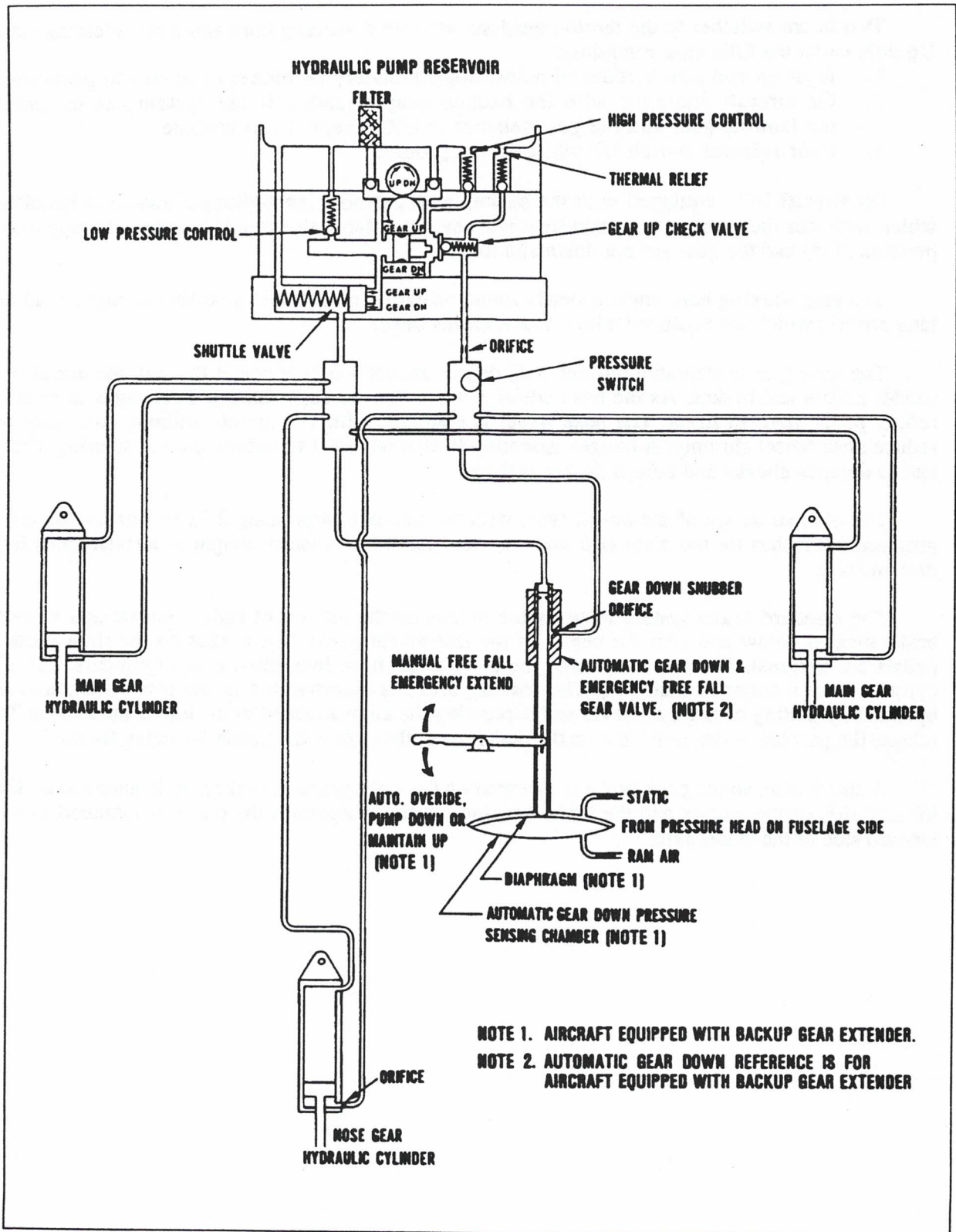

Landing Gear Hydraulic Schematic

## ARROW II

---

Two micro-switches in the throttle quadrant activate a warning horn and a red Warning Gear Up light under the following conditions:

1. Gear up and power reduced below approximately 14 inches of manifold pressure.
2. On aircraft equipped with the backup gear extender, if the system has extended the landing gear and the gear selector is UP, except at full throttle.
3. Gear selector switch UP while on the ground.

On aircraft NOT equipped with the backup gear extender, an additional switch is installed which activates the warning horn and light whenever the flaps are extended beyond the approach position ( $10^\circ$ ) and the gear are not down and locked.

The gear warning horn emits a steady sound on earlier models and a 90 Hz beeping sound on later models which are equipped with a stall warning horn.

The nose gear is steerable through a 30 degree arc each side of center through the use of the rudder pedals and brakes. As the nose wheel retracts, the steering linkage disengages to reduce rudder pedal loads in flight. The nose wheel is equipped with a hydraulic shimmy dampener to reduce nose wheel shimmy. A bungee assembly is also included to reduce ground steering effort and to dampen shocks and bumps during taxiing.

The oleo struts are of the air-oil type, with normal extension being 2.75 inches for the nose gear and 2.0 inches for the main gear under normal static load (empty weight of airplane plus full fuel and oil).

The standard brake system includes toe brakes on the left set of rudder pedals and a hand brake located below and near the center of the instrument panel. Toe brakes on the right rudder pedals are optional. The toe brakes and the hand brake have individual brake cylinders, but all cylinders use a common reservoir. The parking brake is incorporated in the lever brake and is operated by pulling back on the lever and depressing the knob attached to the top of the handle. To release the parking brake, pull back on the brake lever; then allow the handle to swing forward.

A single disc, single puck brake is mounted on the main gears. A brake disc is mounted on the inboard side of the wheels and the brake housing which incorporates the pucks is mounted to the inboard side of the wheel axle.

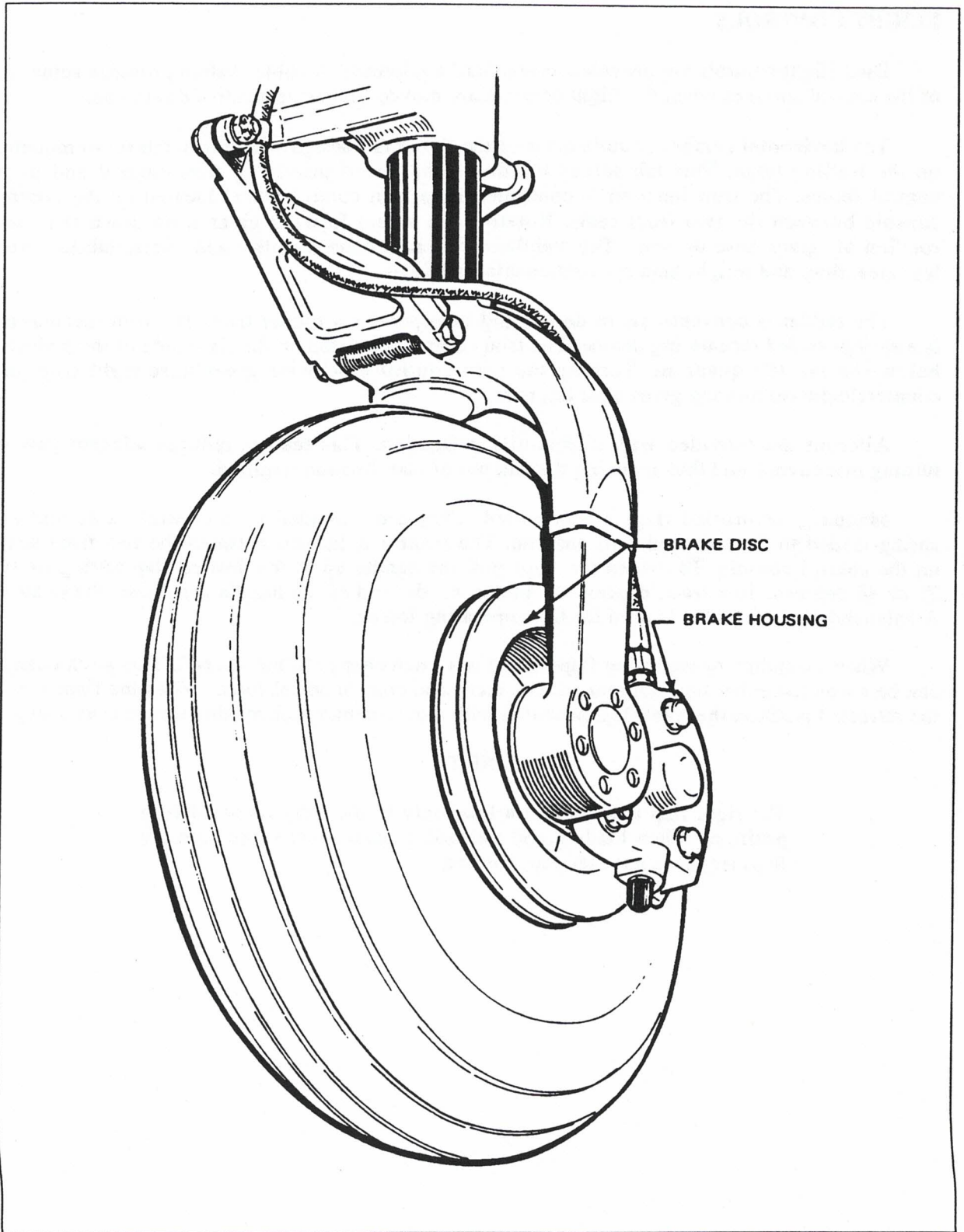

Main Wheel Assembly

### FLIGHT CONTROLS

Dual flight controls are provided as standard equipment. A cable system provides actuation of the control surfaces when the flight controls are moved in their respective directions.

The **horizontal surface** (stabilator) is of the flying tail design with a trim tab/servo mounted on the trailing edge. This tab serves the dual function of providing trim control and pitch control forces. The trim function is controlled by a trim control wheel located on the control console between the two front seats. Rotating the wheel forward gives nose down trim and rotation aft gives nose up trim. The stabilator provides extra stability and controllability with less area, drag and weight than conventional tail surfaces.

The rudder is conventional in design and incorporates a rudder trim. The trim mechanism is a spring-loaded recentering device. The trim control is located on the right side of the pedestal below the throttle quadrant. Turning the trim control clockwise gives nose right trim and counterclockwise rotation gives nose left trim.

Ailerons are provided with differential deflection. This feature reduces adverse yaw in turning maneuvers, and thus reducing the amount of coordination required.

Manually controlled flaps are provided. They are extended by a control cable and are spring-loaded to the retracted (up) position. The control is located between the two front seats on the control console. To extend the flaps pull the handle up to the desired flap setting of 10, 25 or 40 degrees. To retract, depress the button on the end of the handle and lower the control. A balanced control system is used for light operating forces.

When extending or retracting flaps, there is a pitch change in the aircraft. This pitch change can be corrected either by stabilator trim or increased control wheel force. When the flaps are in the retracted position the right flap, provided with a over-center lock mechanism, acts as a step.

#### NOTE

The right flap will support a load only in the fully retracted (up) position. When loading and unloading passengers make sure the flaps are in the retracted (up) position.

## FUEL SYSTEM

The fuel system was designed with simplicity in mind. It incorporates two fuel tanks, one in each wing containing twenty-five (25) U.S. gallons, giving a total of 48 usable gallons. The tanks are attached to the leading edge of the wing with screws and are an integral part of the wing structure. This allows for easy removal for service. An auxiliary electric fuel pump is provided in case of a failure of the engine driven pump. A rocker type switch for controlling the electric pump is located on the switch panel above the throttle quadrant. The electric pump should be on for take-off, switching tanks and during landing.

The fuel **tank selector**, which allows the pilot to control the flow of fuel to the engine, is located on the left side wall below the instrument panel. It has three positions: OFF, LEFT TANK and RIGHT TANK. The arrow on the handle of the selector points to the tank which is supplying fuel to the engine. The valve also incorporates a safety latch which prevents inadvertently selecting the "OFF" position.

Each tank has an individual quick drain located at the bottom inboard rear corner. The fuel strainer also incorporates a quick drain which is located in the left front corner of the firewall. The quick drain protrudes from the cowling to allow easy draining of the fuel strainer. All three drains should be drained before every flight and checked for contamination.

The fuel tanks are vented individually by a vent tube which protrudes below the bottom of the wing at the rear outboard corner of each fuel tank. The vent should be checked periodically to ascertain that the vent is not obstructed and allows free passage of air.

Fuel quantity and pressure are indicated on gauges located in the instrument cluster to the left of the switch panel.

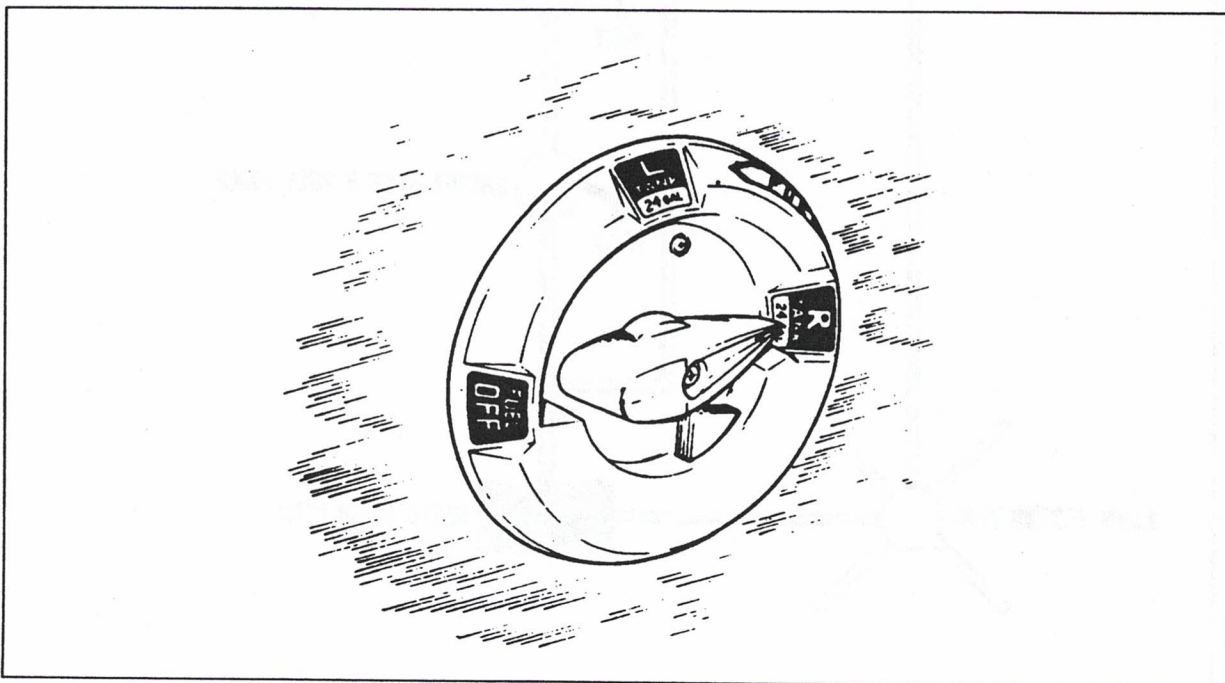

Fuel Selector

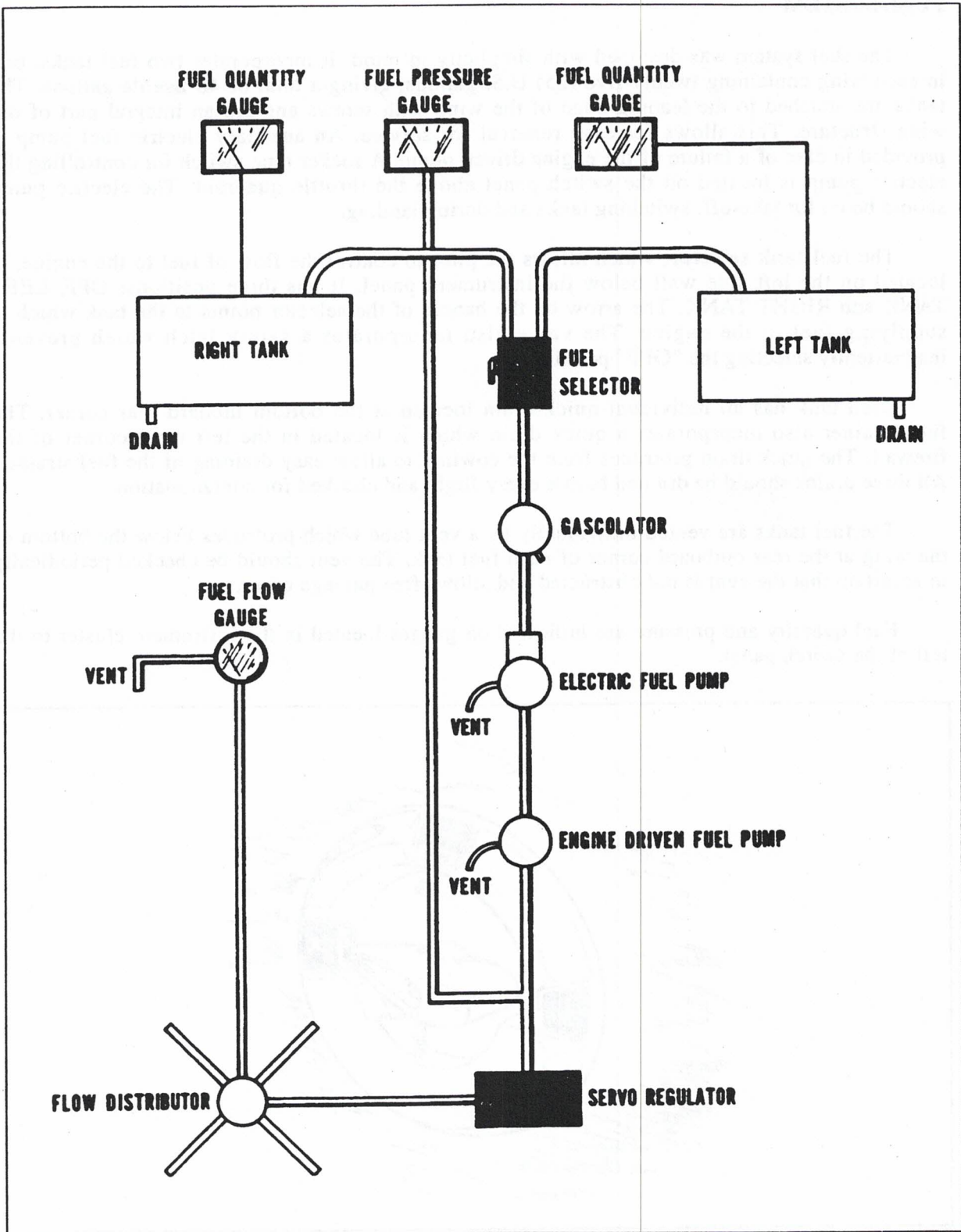

Fuel Schematic

---

## ELECTRICAL SYSTEM

The electrical system is very simple and functional. All switches are grouped in a switch panel above the power quadrant. On the lower right side of the instrument panel is the circuit breaker panel, with each breaker clearly marked to show what circuit it protects. Also, circuit provisions are made to handle a complete complement of communication and navigational equipment.

Standard electrical accessories include alternator, starter, electric fuel pump, stall warning indicator, ammeter, and annunciator panel\*.

The annunciator panel includes alternator and low oil pressure indicator lights. When the optional gyro system is installed, the annunciator panel also includes a low vacuum indicator light. The annunciator panel lights are provided only as a warning to the pilot that a system may not be operating properly, and that he should check and monitor the applicable system gauge to determine when or if any necessary action is required.

Optional electrical accessories include navigation, anti-collision, landing, instrument and cabin dome lights. Navigation and radio lights are controlled by a rheostat switch on the left side of the switch panel. The instrument panel lights are controlled by a rheostat switch on the right side of the panel.

### WARNING

When optional panel lights are installed, rheostat switch must be off to obtain gear lights full intensity during daytime flying. When aircraft is operated at night and panel light rheostat switch is turned on, gear lights will automatically dim.

The anti-collision and landing lights are controlled by rocker switches on the switch panel. Circuits will handle a full complement of communications and navigational equipment.

### WARNING

Strobe lights should not be operating when flying through overcast and clouds since reflected light can produce spacial disorientation. Do not operate strobe lights in close proximity to ground, during takeoff and landing.

The master switch, also located in the switch panel, is a split rocker switch. One side of the switch is the battery side ("BAT") and the other is the alternator side ("ALT"). Henceforth, "master switch," used in this manual, shall mean both "BAT" and "ALT" switches. The "ALT" switch is provided for an emergency and its function is covered under "Alternator Failure" in the Emergency section of the handbook.

The primary electrical power source is a 14-volt, 60-amp alternator, which is protected by a voltage regulator and an overvoltage relay. The alternator provides full electrical power output even at low engine RPM. This provides improved radio and electrical equipment operation and increases battery life by reducing battery load.

\*Serial nos. 7535001 and up

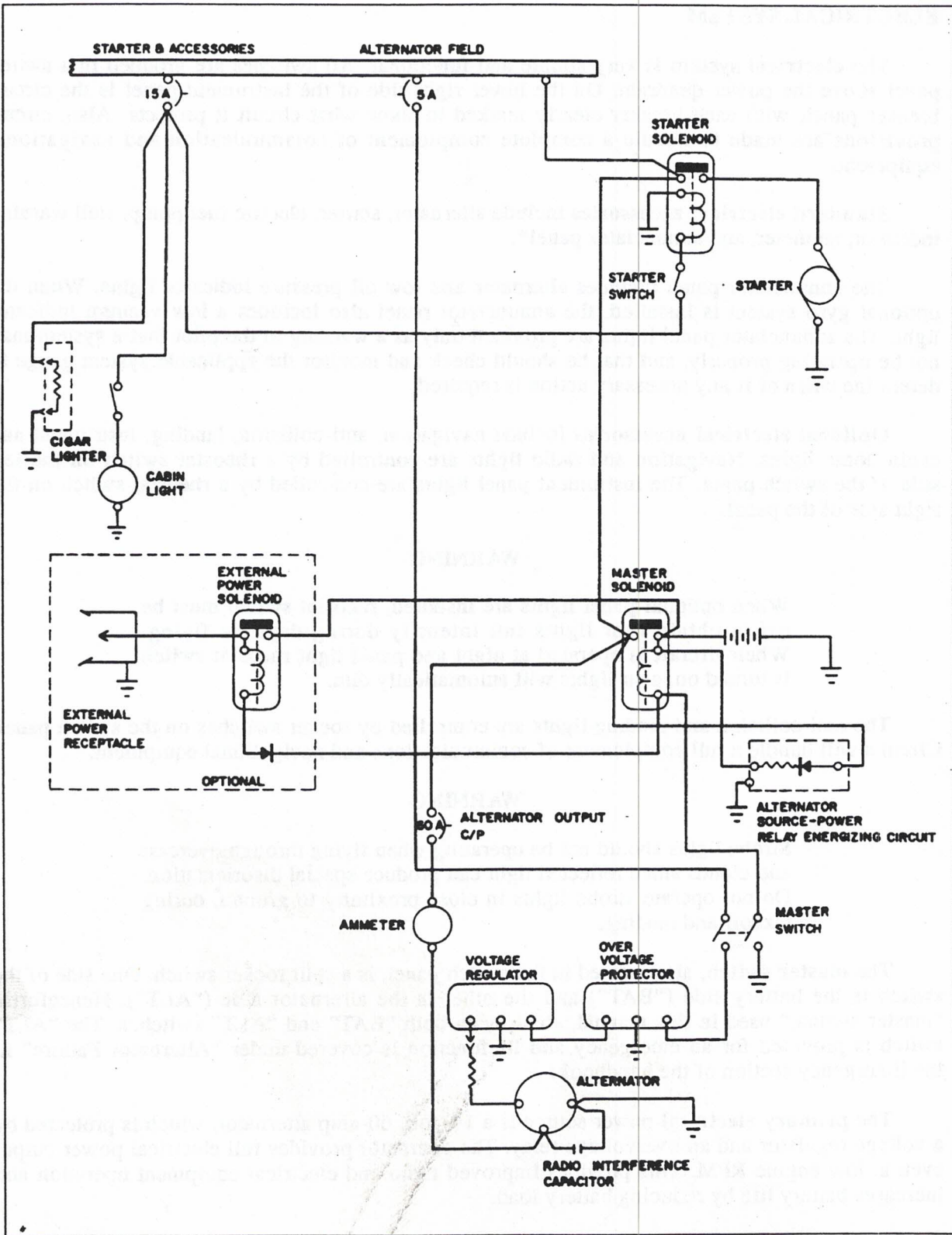

Alternator and Starter Schematic (Ser. Nos. 7435001 through 7435331)

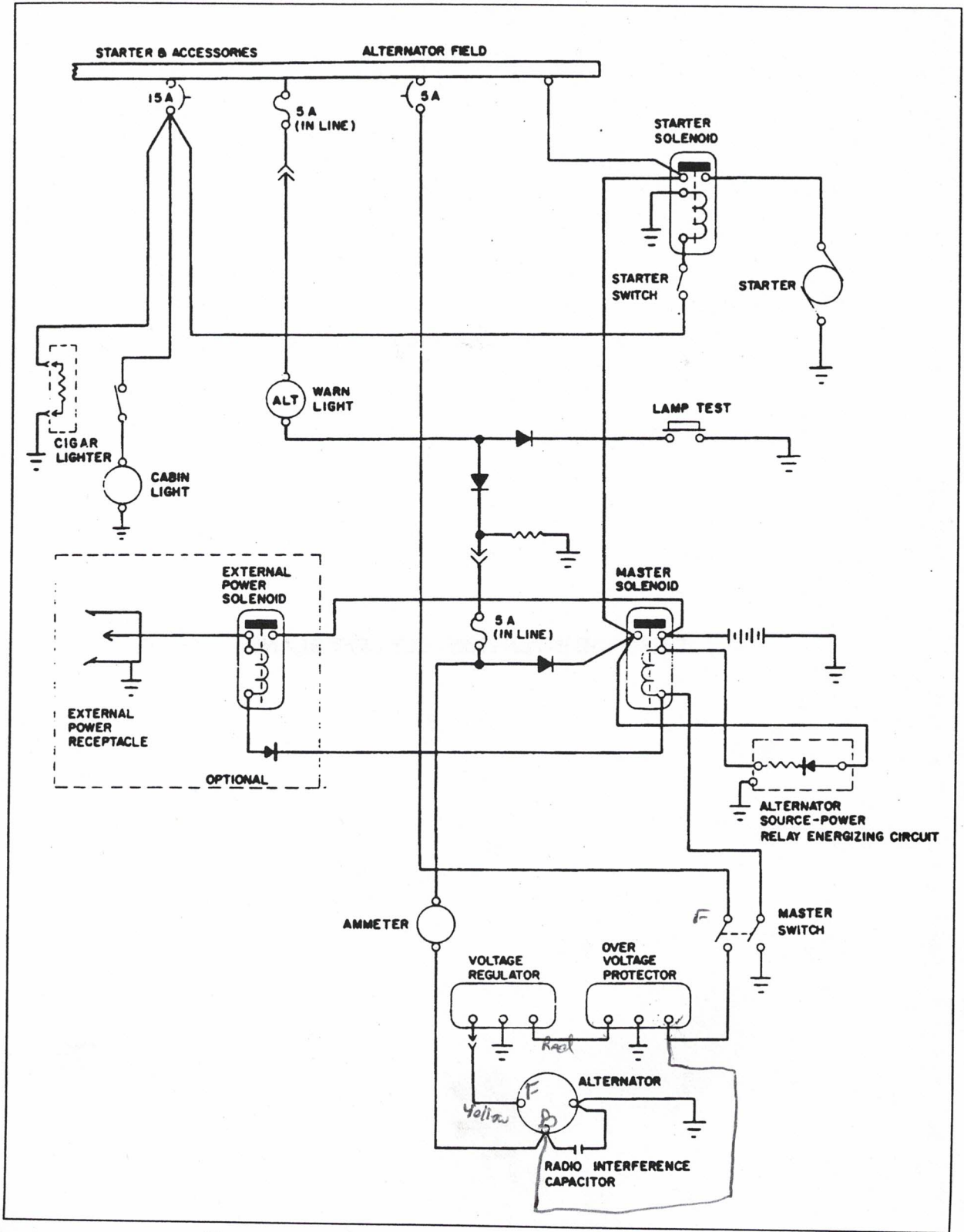

Alternator and Starter Schematic (Ser. Nos. 7535001 and up)

THIS PAGE INTENTIONALLY LEFT BLANK

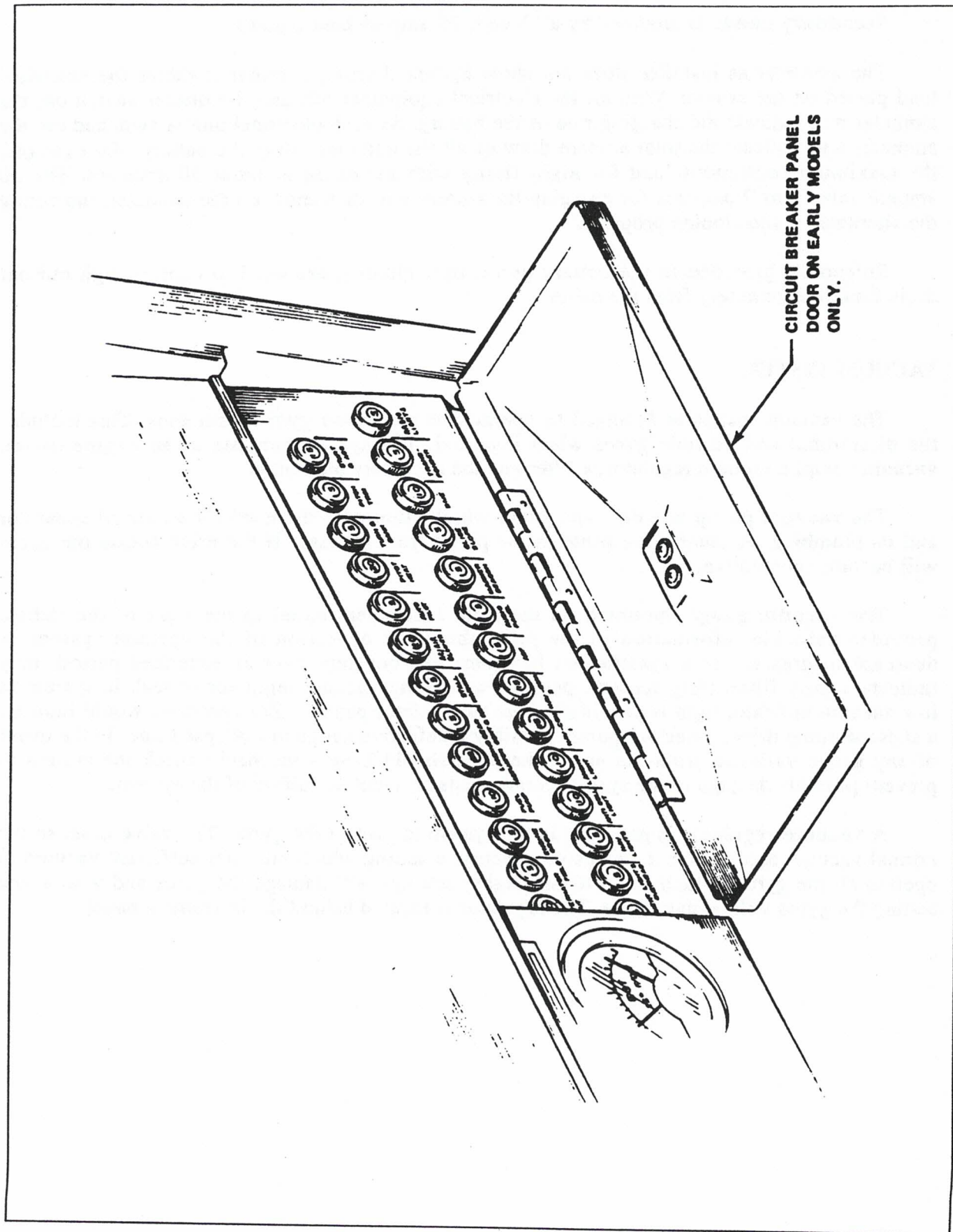

Circuit Breaker Panel

**Secondary power** is provided by a 12-volt, 25-ampere hour battery.

The ammeter as installed does not show battery discharge; rather it shows the electrical load placed on the system. With all the electrical equipment off, and the master switch on, the ammeter will indicate the charging rate of the battery. As each electrical unit is switched on, the ammeter will indicate the total ampere draw of all the units including the battery. For example, the maximum continuous load for night flying with radios on is about 30 amperes. The 30 ampere value plus 2 amperes for charging the battery will then show on the ammeter, indicating the alternator is functioning properly.

Solenoids, provided in the battery and starter circuits, are used to control high current drain functions remotely from the cabin.

### VACUUM SYSTEM

The vacuum system is designed to operate the air driven gyro instruments. This includes the directional and attitude gyros when installed. The system consists of an engine driven vacuum pump, a vacuum regulator, a filter and the necessary plumbing.

The **vacuum pump** is a dry type pump which eliminates the need for an air/oil separator and its plumbing. A shear drive protects the pump from damage. If the drive shears the gyros will become inoperative.

The **vacuum gauge**, mounted on the right instrument panel to the right of the radios, provides valuable information to the pilot about the operation of the vacuum system. A decrease in pressure in a system that has remained constant over an extended period, may indicate a dirty filter, dirty screens, possibly a sticking vacuum regulator or leak in system (a low vacuum indicator light is provided in the annunciator panel\*). Zero pressure would indicate a sheared pump drive, defective pump, possibly a defective gauge or collapsed line. In the event of any gauge variation from the norm, the pilot should have a mechanic check the system to prevent possible damage to the system components or eventual failure of the system.

A **vacuum regulator** is provided in the system to protect the gyros. The valve is set so the normal vacuum reads  $5.0 \pm .1$  inches of mercury, a setting which provides sufficient vacuum to operate all the gyros at their rated RPM. Higher settings will damage the gyros and with a low setting the gyros will be unreliable. The regulator is located behind the instrument panel.

\*Serial nos. 7535001 and up

---

## INSTRUMENT PANEL

The instrument panel is designed to be functional and professional, accommodating complete instruments and avionics equipment for VFR and IFR flights. A wide range of optional instruments and avionics permits an equipment selection uniquely suited to individual needs.

**Flight instruments** are grouped in a standard "T" directly in front of the pilot. Radio navigational indicators are to the right of the flight instruments and are located to correspond to the respective radio control heads. Fuel gauges are located to the right of the pilot control wheel and engine instruments are located to the left of the control wheel. The tachometer and manifold pressure instruments are located to the left of the power quadrant and are positioned respective of the throttle and propeller controls.

The circuit breakers are protected by a cover door.

The climatic controls, when the air conditioning system is installed, are located in the right instrument panel above the circuit breakers.

An annunciator panel\* is mounted in the upper instrument panel to warn the pilot of a possible malfunction in the alternator, oil pressure or vacuum systems.

## PITOT-STATIC SYSTEM

The system supplies both pitot and static pressure for the airspeed indicator, altimeter and vertical speed indicator (when installed).

Pitot and static pressure are picked up by the pitot head on the bottom of the left wing. An optional heated pitot head, which alleviates problems with icing or heavy rain, is available. The switch for pitot heat is located on the lower left instrument panel.

To prevent bugs and water from entering the pitot and static pressure holes, a cover should be placed over the pitot head. A partially or completely blocked pitot head will give erratic or zero readings on the instruments.

### NOTE

During the preflight, check to make sure the pitot cover is removed.

\*Serial nos. 7535001 and up

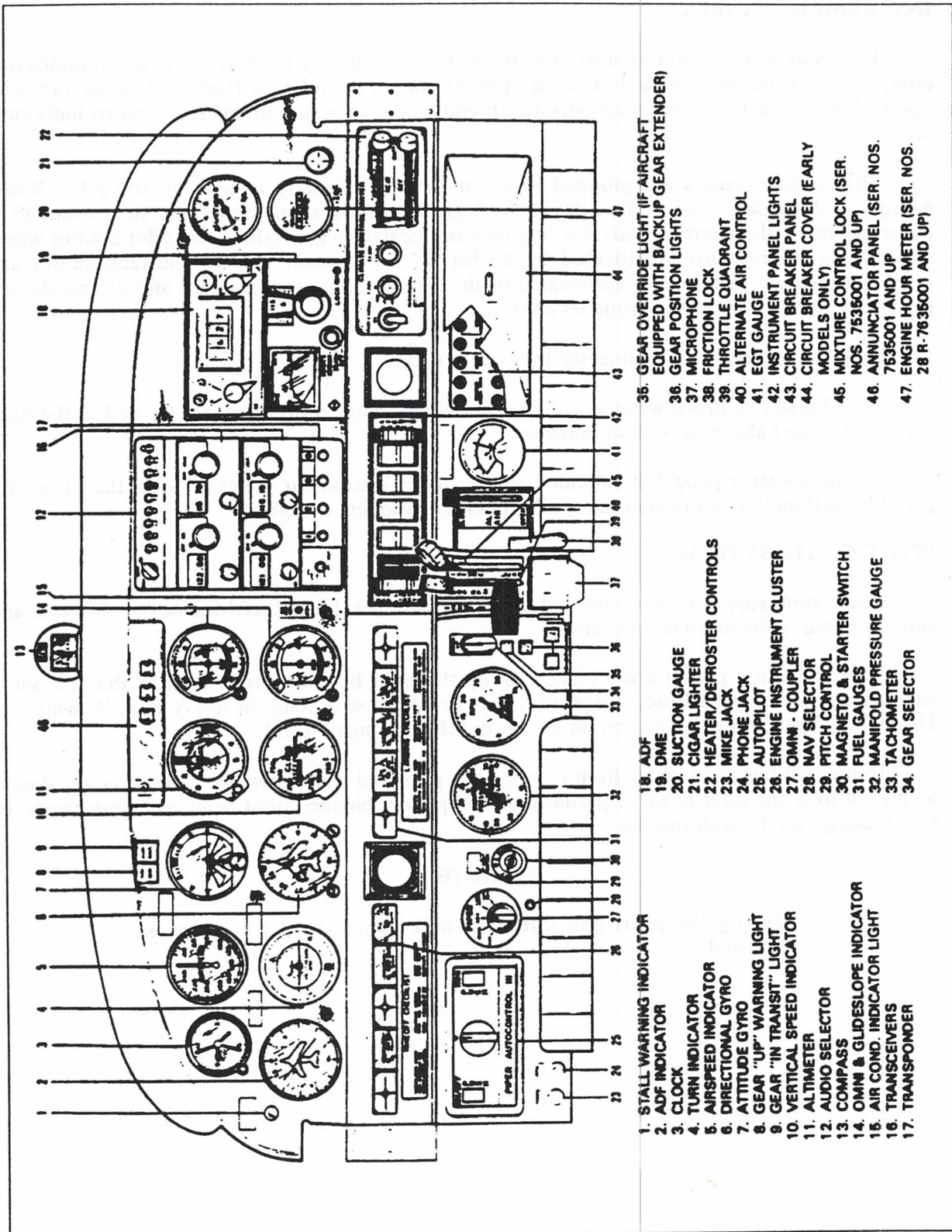

Instrument Panel

- 1. STALL WARNING INDICATOR
- 2. ADF INDICATOR
- 3. CLOCK
- 4. TURN INDICATOR
- 5. AIRSPEED INDICATOR
- 6. DIRECTIONAL GYRO
- 7. ATTITUDE GYRO
- 8. GEAR "UP" WARNING LIGHT
- 9. GEAR "IN TRANSIT" LIGHT
- 10. VERTICAL SPEED INDICATOR
- 11. ALTIMETER
- 12. AUDIO SELECTOR
- 13. COMPASS
- 14. OMNI & GLIDESLOPE INDICATOR
- 16. AIR COND. INDICATOR LIGHT
- 17. TRANSPONDER
- 18. ADF
- 19. DME
- 20. SUCTION GAUGE
- 21. CIGAR LIGHTER
- 22. HEATER/DEFROSTER CONTROLS
- 23. MIKE JACK
- 24. PHONE JACK
- 25. AUTOPILOT
- 26. ENGINE INSTRUMENT CLUSTER
- 27. OMNI - COUPLER
- 28. NAV SELECTOR
- 29. PITCH CONTROL
- 30. MAGNETO & STARTER SWITCH
- 31. FUEL GAUGES
- 32. MANIFOLD PRESSURE GAUGE
- 33. TACHOMETER
- 34. GEAR SELECTOR
- 35. GEAR OVERRIDE LIGHT (IF AIRCRAFT EQUIPPED WITH BACKUP GEAR EXTENDER)
- 36. GEAR POSITION LIGHTS
- 37. MICROPHONE
- 38. FRICTION LOCK
- 39. THROTTLE QUADRANT
- 40. ALTERNATE AIR CONTROL
- 41. EGT GAUGE
- 42. INSTRUMENT PANEL LIGHTS
- 43. CIRCUIT BREAKER PANEL
- 44. CIRCUIT BREAKER COVER (EARLY MODELS ONLY)
- 45. MIXTURE CONTROL LOCK (SER. NOS. 7535001 AND UP)
- 46. ANNUNCIATOR PANEL (SER. NOS. 7535001 AND UP)
- 47. ENGINE HOUR METER (SER. NOS. 28 R-7635001 AND UP)

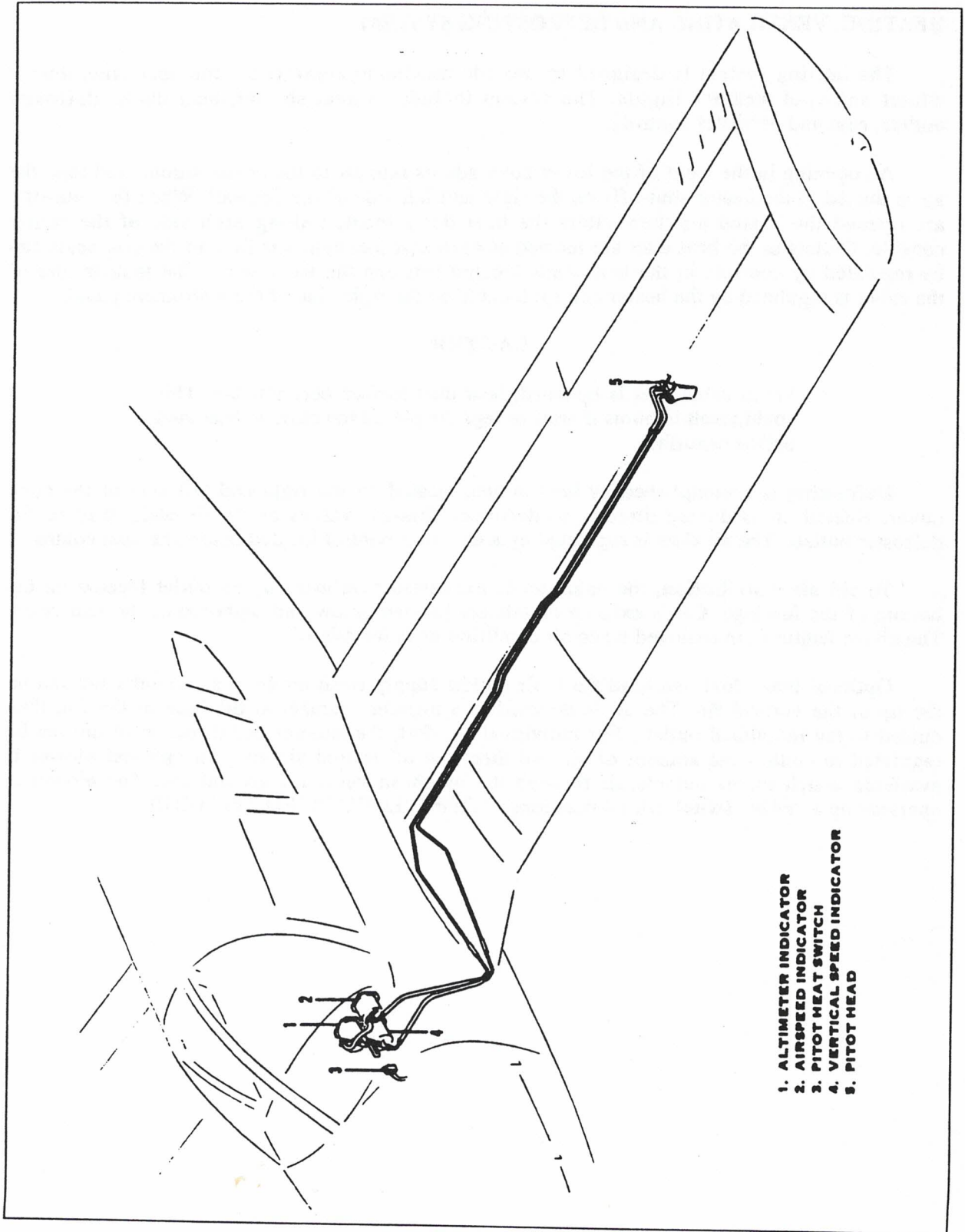

Pitot - Static System

## HEATING, VENTILATING AND DEFROSTING SYSTEM

The heating system is designed to provide maximum comfort for the occupants during winter and cool weather flights. The system includes a heat shroud, heat ducts, defroster outlets, heat and defroster controls.

An opening in the front of the lower cowl admits ram air to the heater shroud and then the air is ducted to the heater shut-offs on the right and left side of the firewall. When the shut-offs are opened the heated air then enters the heat ducts located along each side of the center console. Outlets in the heat duct are located at each seat location. Air flow to the rear seats can be regulated by controls in the heat ducts located between the front seats. The temperature of the cabin is regulated by the heater control located on the right side of the instrument panel.

### CAUTION

When cabin heat is operated, heat duct surface becomes hot. This could result in burns if arms or legs are placed too close to heat duct outlets or surface.

**Defrosting** is accomplished by heat outlets located on the right and left side of the cowl cover. Heated air is ducted directly to defroster shut-off valves at the firewall, then to the defroster outlets. The air flow is regulated by a defroster control located below the heat control.

To aid **air distribution**, the cabin air is exhausted overboard by an outlet located on the bottom of the fuselage. Cabin exhaust outlets are located below and outboard of the rear seats. The above features are removed when air conditioning is installed.

Optional individual overhead fresh air outlets supply fresh air from an air inlet located on the tip of the vertical fin. The air is directed to a plenum chamber at the base of the fin, then ducted to the individual outlets. For individual comfort, the amount and direction of air can be regulated to control the amount of air and direction of desired airflow. An optional blower is available which forces outside air through the overhead vents for ground use. The blower is operated by a "FAN" switch with 4 positions - "OFF," "LOW," "MED," or "HIGH."

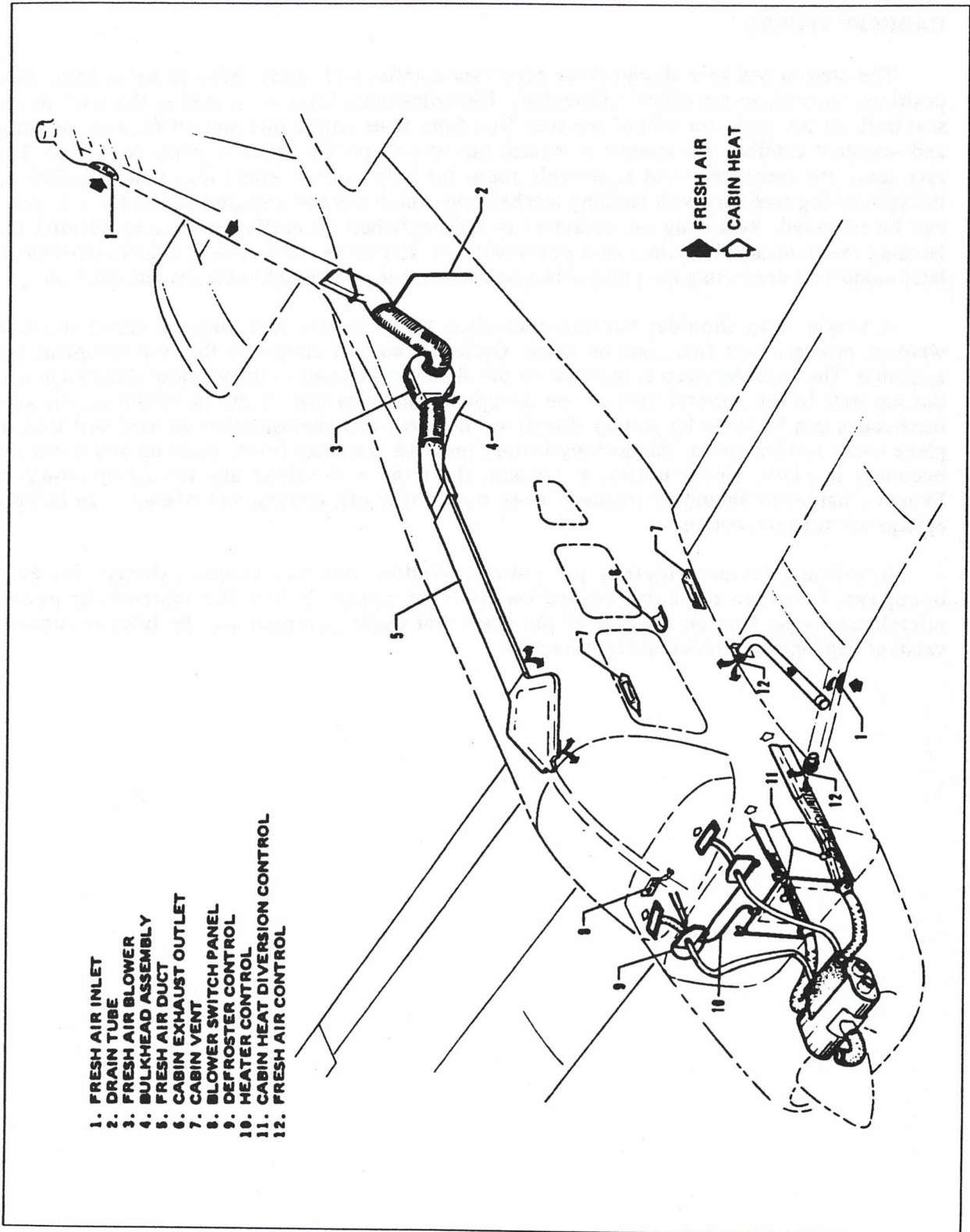

Heating and Ventilating System

## CABIN FEATURES

The interior has been designed for passenger comfort and safety. All seat backs have three positions: normal, intermediate and recline. The adjustment lever is located at the base of the seat back on the outboard side of the seat. The front seats adjust fore and aft for ease of entry and occupant comfort. An armrest is located on the side panels adjacent to the front seat. The rear seats are easily removed to provide room for bulky items. Some rear seat installations incorporate leg retainers with latching mechanisms which must be released before the rear seats can be removed. Releasing the retainers is accomplished on earlier models by turning the latching mechanisms 90° with a coin or screwdriver. Releasing the retainers is accomplished on later models by depressing the plunger behind each rear leg. Optional headrests are available.

A single strap shoulder harness controlled by an inertia reel, located above the side window, protects each front seat occupant. Optional shoulder straps for the rear occupants are available. The shoulder strap is routed over the shoulder adjacent to the window and attached to the lap belt in the general area of the occupant's inboard hip. A check of the inertia reel mechanism can be made by pulling sharply on the strap and checking that the reel will lock in place under sudden stress; this locking feature prevents the strap from extending and holds the occupant in place. Under normal movement the strap will extend and retract as required. Shoulder harnesses should be routinely worn during take-off, landing and whenever an inflight emergency situation occurs.

Additional features include pilot storm window, two sun visors, ashtrays for each occupant, two map pockets located on the side panels below the instrument panel, miscellaneous pockets on the rear of the front seat backs, armrests for the front occupants, cabin or baggage door locks and ignition lock.

---

## BAGGAGE AREA

A large baggage area, located behind the rear seats, is accessible either from the cabin or through a large outside baggage door on the right side of the aircraft. Maximum capacity is 200 lbs. Tie-down straps are provided and should be used at all times.

## NOTE

It is the pilot's responsibility to be sure when the baggage is loaded that the aircraft C.G. falls within the allowable C.G. Range. (See Weight and Balance Section.)

## STALL WARNING

An approaching stall is indicated by a stall warning indicator which is activated between five and ten miles per hour above stall speed. Mild airframe buffeting and gentle pitching may also precede the stall. Stall speeds are shown on graphs in the Performance Charts Section. The stall warning indicator is a red warning light on the left side of the instrument panel on earlier models and a continuous sounding horn located behind the instrument panel on later models. The landing gear horn is different in that it emits a 90 cycles per minute beeping sound on later models. The stall warning indicator is activated by a lift detector installed on the leading edge of the left wing. During preflight, the stall warning system should be checked by turning the master switch "ON," lifting the detector and checking to determine if the indicator is actuated.

## FINISH

The exterior of the aircraft is finished with a durable acrylic lacquer in a variety of tasteful colors to suit individual owners.

## AIR CONDITIONING\*

The air conditioning system is a recirculating air system. The major items include; evaporator, condenser, compressor, blower, switches and temperature controls.

The evaporator is located behind the left rear side of the baggage compartment. This cools the air that is used for air conditioning.

The condenser is mounted on a retractable scoop located on the bottom of the fuselage and to the rear of the baggage compartment area. The scoop extends when the air conditioner is "ON" and retracts to a flush position when the system is "OFF."

The compressor is mounted on the forward right underside of the engine. It has an electric clutch which automatically engages or disengages the compressor to the belt drive system of the compressor.

\*Optional Equipment

THIS PAGE INTENTIONALLY LEFT BLANK

An electrical blower is mounted on the aft side of the rear cabin panel. Air from the baggage area is drawn through the evaporator by the blower and distributed through an overhead duct to individual outlets located adjacent to each occupant.

The switches and temperature control are located on the lower right side of the instrument panel in the climate control center panel. The temperature control regulates the desired temperature of the cabin. Turn the control clockwise for increased cooling, counterclockwise for decreased cooling.

Located inboard of the temperature control is the fan speed switch and the air conditioning "ON-OFF" switch. The fan can be operated independently of the air conditioning. However, it must be on for air conditioner operation. Turning either switch off will disengage the compressor clutch and retract the condenser door. Cooling air should be felt within one minute after the air conditioner is turned on.

#### NOTE

If the system is not operating in 5 minutes turn the system "OFF," until the fault is corrected.

The "FAN" switch allows operation of the fan with the air conditioner turned "OFF" to aid cabin air circulation if desired. A "LOW," "MED" or "HIGH" flow of air can be selected to the air conditioner outlets located in the overhead duct. The outlets can be adjusted or turned off by each occupant to obtain individual cooling effect.

The condenser door light is located to the left of the radio stack in front of the pilot. The door light illuminates and remains on when the door is open or extended. The light is off when the door is retracted.

A circuit breaker located on the circuit breaker panel protects the air conditioning electrical system.

Whenever the throttle is in the full throttle position, it actuates a micro switch which disengages the compressor and retracts the scoop. This is done to obtain maximum power and maximum rate of climb. The fan continues to operate and the air will remain cool for approximately one minute. When the throttle is retarded approximately 1/4 inch, the clutch will engage and the scoop will extend, again supplying cool, dry air.

#### PIPER EXTERNAL POWER\*

An optional starting installation known as Piper External Power (PEP) is accessible through a receptacle located on the right side of the fuselage aft of the wing. An external battery can be connected to the socket, thus allowing the operator to crank the engine without having to gain access to the airplane's battery.

\*Optional Equipment

THIS PAGE INTENTIONALLY LEFT BLANK

DUPLICATE

# AIRPLANE FLIGHT MANUAL

FOR

# CHEROKEE ARROW

## WARNING

EXTREME CARE MUST BE EXERCISED TO LIMIT THE USE OF THIS MANUAL TO APPLICABLE AIRCRAFT. THIS MANUAL REVISED AS INDICATED BELOW OR SUBSEQUENTLY REVISED IS VALID FOR USE WITH THE AIRPLANE IDENTIFIED BELOW WHEN APPROVED BY PIPER AIRCRAFT CORPORATION. SUBSEQUENT REVISIONS SUPPLIED BY PIPER AIRCRAFT CORPORATION MUST BE PROPERLY INSERTED.

MODEL PA-28R-200

AIRCRAFT SERIAL NO. 28R-7635337 REGISTRATION NO. N6828J

AIRPLANE FLIGHT MANUAL, REPORT NUMBER VB-560 REVISION 7

PIPER AIRCRAFT CORPORATION  
APPROVAL SIGNATURE AND STAMP *H. W. Barnhouse*



## NOTE

THIS MANUAL MUST BE KEPT IN THE AIRPLANE AT ALL TIMES

FAA APPROVED BY:

*H. W. Barnhouse*

H. W. BARNHOUSE  
PIPER AIRCRAFT CORPORATION  
D. O. A. No. SO-1  
VERO BEACH, FLORIDA

DATE OF APPROVAL: MAY 14, 1973

APPROVAL BASIS: CAR 3 AND FAR PART 21, SUBPART J.

REPORT: VB-560  
MODEL: PA-28R-200

AIRPLANE FLIGHT MANUAL

CHEROKEE ARROW

WARNING

ATTENTION MUST BE GIVEN TO THE USE OF THIS MANUAL TO AVOID AIRCRAFT DAMAGE. THIS MANUAL REVISED AS INDICATED BELOW IS THE ONLY AUTHORITY TO BE USED FOR USE WITH THE AIRPLANE. ANY OTHER INFORMATION NOT APPROVED BY THE AIRCRAFT CORPORATION IS NOT TO BE USED.

MODEL NUMBER \_\_\_\_\_

REGISTRATION NO. \_\_\_\_\_

DATE OF REVISION \_\_\_\_\_

\_\_\_\_\_

# AIRPLANE FLIGHT MANUAL

Log of Revisions.....	3-iii
Limitations .....	3-1
Procedures .....	3-7
Emergency Procedures .....	3-11
Performance .....	3-13
Supplements .....	3-15





## TABLE OF CONTENTS

Log of Revisions.....	3-iii
 <b>SECTION I</b>	
Limitations .....	3-1
A. Engines.....	3-1
B. Fuel .....	3-1
C. Propellers .....	3-1
D. Instrument Markings (Power Plant).....	3-1
E. Airspeed Limitations and Instrument Markings (Calibrated Airspeed) .....	3-2
F. Flight Load Factors.....	3-2
G. Maximum Weight .....	3-2
H. Baggage Capacity .....	3-2
I. C. G. Range.....	3-2
J. Maneuvers.....	3-3
K. Placards.....	3-3
 <b>SECTION II</b>	
Procedures.....	3-7
A. System Operations .....	3-7
B. Emergency Procedures.....	3-11
 <b>SECTION III</b>	
Performance .....	3-13
A. Stalls.....	3-13
 <b>SECTION IV</b>	
Optional Equipment .....	3-15
A. Electric Pitch Trim Installation.....	3-17
B. AutoFlite II Installation .....	3-19
C. Air Conditioner Installation .....	3-20
D. Installation of Piper AutoControl III and/or AutoControl IIIB .....	3-21

TABLE OF CONTENTS

THIS PAGE INTENTIONALLY LEFT BLANK

## AIRPLANE FLIGHT MANUAL LOG OF REVISIONS

Revision	Revised Pages	Description and Revision	FAA Approved Date
1	Title	Added PAC Approval Form. (NOTE: AIRCRAFT DELIVERED WITH MANUALS PRIOR TO THIS REVISION DO NOT REQUIRE THIS REVISION.)	 D. H. Trompler March 25, 1974
2	3-i 3-7 3-8 3-15 3-21, 3-22, 3-23, 3-24	Added Item E., AutoControl IIIB to Supplements. Added Gear Light Warning to Item 4. (b); Relocated Items 4. (c) and 4. (d). Added Info from Page 3-7. Added Item E., Installation of Piper AutoControl IIIB. Added pages (AutoControl IIIB Supplement info added).	 D. H. Trompler June 18, 1974
3	3-i 3-15 3-17 3-18 3-19 3-20 3-21 3-24	Revised Section IV Title (Supplements to Optional Equipment); deleted item B. (AutoControl III); revised existing item letters; added AutoControl III to new item D. Revised Section IV Title (Supplements to Optional Equipment); revised Note; deleted item B. (AutoControl III); revised existing item letters; added AutoControl III to new item D. Revised item A. (Electric Pitch Trim Installation) info. Delete item B. (AutoControl III). Revised item letter (C. to B.); revised item 2. b (1); added new item (2); revised existing item nos. Revised item letter (D. to C.). Revised item letter (E. to D.); added AutoControl III to Title. Deleted IIIB designation from item nos. c. (1) and c. (2).	 Ward Evans June 27, 1975

## AIRPLANE FLIGHT MANUAL LOG OF REVISIONS (cont.)

Revision	Revised Pages	Description and Revision	FAA Approved Date
4	3-24	Revised Item c. (1).	<i>Ward Evans</i> Ward Evans Dec. 8, 1975
5	3-1 3-11	Added Lycoming OI-360-C1C6 Engine and McCauley Propeller; added Tachometer Green Arc for McCauley prop. Added info to item B.1. (Emergency Landing Gear Extension).	<i>Ward Evans</i> Ward Evans Feb. 28, 1977
6	3-1	Revised item B.	<i>Ward Evans</i> Ward Evans Feb. 29, 1984
7	3-4 3-7,3-8 3-11	Added placard note. Revised landing gear system operation. Revised emergency landing gear extension procedures.	<i>D.H. Trompler</i> D.H. Trompler May 14, 1987

## SECTION 1

### LIMITATIONS

The following limitations must be observed in the operation of this airplane:

#### A. ENGINE

Lycoming IO-360-C1C (Serial Nos. 28R-7435001 through 28R-7635516)  
Lycoming IO-360-C1C6 (Serial Nos. 28R-7635517 and up)

##### ENGINE LIMITS

For all operations 2700 RPM 200 HP

#### B. FUEL (AVGAS ONLY)

100/130 Octane Aviation Gasoline (Minimum)

#### C. PROPELLER - S/N 28R-7435001 thru 28R-7635516

Hartzell HC-C2HK-1( )/7666A-2 or  
Hartzell HC-C2YK-1( )F/F7666A-2

Pitch Settings at 30 in. Station:

High  $29.0 \pm 2.0$

Low  $14 \pm 0.2$

Diameter: Maximum 74 inches

Minimum 72.5 inches

(Avoid continuous operation  
2100-2350 RPM)

S/N 28R-7635517 and up  
McCauley B2D34C213/90DHA-16

Pitch Settings at 30 in. Station:

High  $29.8 \pm 0.5$

Low  $12.5 \pm 0.2$

Diameter: Maximum 74 inches

Minimum 73 inches

(Avoid continuous operation  
between 1500 and 1950 RPM  
below 15 inches manifold pressure.)

#### D. INSTRUMENT MARKINGS (Power Plant)

##### OIL TEMPERATURE

Green Arc (Normal Operating Range)

75°F to 245°F

Red Line (Maximum)

245°F

##### OIL PRESSURE

Green Arc (Normal Operating Range)

60 PSI to 90 PSI

Yellow Arc (Caution Range)

25 PSI to 60 PSI

Red Line (Minimum)

25 PSI

Red Line (Maximum)

90 PSI

##### FUEL PRESSURE

Green Arc (Normal Operating Range)

14 PSI to 45 PSI

Red Line (Minimum)

14 PSI

Red Line (Maximum)

45 PSI

##### TACHOMETER

Serial Nos. 28R-7435001 thru 28R-7635516

Green Arc (Normal Operating Range)

500 to 2100 and 2350 to 2700 RPM

Red Arc

2100 to 2350 RPM

Red Line (Maximum Continuous Power)

2700 RPM

Serial Nos. 28R-7635517 and up

Green Arc (Normal Operating Range)

500 to 2700 RPM

Red Line (Maximum Continuous Power)

2700 RPM

**ARROW**

**E. AIRSPEED LIMITATIONS AND INSTRUMENT MARKINGS (Calibrated Airspeed)**

NEVER EXCEED SPEED	214 MPH
MAXIMUM STRUCTURAL CRUISE SPEED	170 MPH
MANEUVERING SPEED	131 MPH
FLAPS EXTENDED SPEED	125 MPH
MAXIMUM GEAR EXTENSION SPEED	150 MPH
MAXIMUM GEAR RETRACTION SPEED	125 MPH

**AIRSPEED INSTRUMENT MARKINGS**

Red Radial Line (Never Exceed)	214 MPH (186 KT)
Yellow Arc (Caution Range) (Smooth Air Only)	170 MPH to 214 MPH (148 KT to 186 KT)
Green Arc (Normal Operating Range)	71 MPH to 170 MPH (62 KT to 148 KT)
White Arc (Flap Down Range)	64 MPH to 125 MPH (56 KT to 109 KT)

**F. FLIGHT LOAD FACTORS**

Positive Load Factor (Maximum)	3.8 G
Negative Load Factor (Maximum)	No inverted maneuvers approved

**G. MAXIMUM WEIGHT**

2650 LBS

**H. BAGGAGE CAPACITY**

200 LBS

**I. C. G. RANGE**

Weight Pounds	Forward Limit Inches Aft of Datum	Rearward Limit Inches After of Datum
2650	87.3	93.0
2300	82.0	93.0
1800	80.0	93.0

**NOTES**

1. Straight line variation between points given.
2. The datum used is 78.4 inches ahead of the wing leading edge at the intersection of the straight and tapered section.
3. It is the responsibility of the airplane owner and the pilot to insure that the airplane is properly loaded. See "Weight and Balance Section" for proper loading instructions.

**J. MANEUVERS**

All acrobatic maneuvers including spins prohibited.

**K. PLACARDS**

In full view of the pilot:

“THIS AIRCRAFT APPROVED FOR NIGHT IFR NON-ICING FLIGHT WHEN EQUIPPED IN ACCORDANCE WITH FAR 91 OR FAR 135.”

“THIS AIRCRAFT MUST BE OPERATED AS A NORMAL CATEGORY AIRPLANE IN COMPLIANCE WITH THE OPERATING LIMITATIONS STATED IN THE FORM OF PLACARDS, MARKINGS AND MANUALS.”

In full view of the pilot, the following takeoff and landing check lists will be installed:

TAKEOFF CHECK LIST		
Fuel on Proper Tank	Mixture - Set	Flaps - Set
Electric Fuel Pump - On	Propeller - Set	Trim Tab - Set
Engine Gauges - Checked	Fasten Belts/Harness	Controls - Free
Alternate Air - Closed		Door - Latched
Seat Backs Erect		Air Conditioner - Off
LANDING CHECK LIST		
Fuel on Proper Tank	Electric Fuel Pump - On	Gear Down (150 MPH Max)
Seat Back Erect	Mixture - Rich	Flaps - Set (125 MPH)
Fasten Belts/Harness	Propeller - Set	Air Conditioner - Off

The “AIR CONDITIONER OFF” item in the above takeoff and landing check lists is mandatory for air conditioned aircraft only.

In full view of the pilot:

“NO ACROBATIC MANEUVERS INCLUDING SPINS APPROVED.”

On the instrument panel in full view of the pilot:

“MANEUVERING SPEED – 131 MPH.”

On the instrument panel in full view of the pilot:

“DEMONSTRATED CROSSWIND COMPONENT – 20 MPH.”

**ARROW**

---

Adjacent to upper door latch:

**"ENGAGE LATCH BEFORE FLIGHT"**

On the inside of the baggage compartment door:

**"BAGGAGE MAXIMUM 200 LBS. SEE WEIGHT AND  
BALANCE DATA FOR BAGGAGE LOADINGS BETWEEN  
150 LBS AND 200 LBS."**

Near emergency gear lever:

**"EMERGENCY DOWN"**

Near emergency gear lever (aircraft equipped with backup gear extender):

**"OVERRIDE ENGAGED AUTO-EXT-OFF  
LOCK PIN ON SIDE  
TO ENGAGE OVERRIDE:  
PULL LEVER FULL UP, PUSH LOCK PIN  
TO RELEASE OVERRIDE:  
PULL LEVER FULL UP & RELEASE"**

Near landing gear selector switch:

<b>"GEAR UP</b>	<b>125 MPH MAX"</b>
<b>"DOWN</b>	<b>150 MPH MAX"</b>

In full view of the pilot when AutoFlite is installed:

**"FOR HEADING CHANGES: PRESS DISENGAGE SWITCH  
ON CONTROL WHEEL. CHANGE HEADING, RELEASE  
DISENGAGE SWITCH."**

On the instrument panel in full view of the pilot when the oil cooler winterization kit is installed:

**"OIL COOLER WINTERIZATION PLATE TO BE  
REMOVED WHEN AMBIENT TEMPERATURE EXCEEDS  
50° F."**

On the instrument panel in full view of the pilot when the supplementary white strobe lights are installed:

**"WARNING - TURN OFF STROBE LIGHTS WHEN  
TAXIING IN VICINITY OF OTHER AIRCRAFT, OR  
DURING FLIGHT THROUGH CLOUD, FOG OR HAZE."**

In full view of the pilot in the area of the air conditioner controls when the air conditioner is installed:

**“WARNING - AIR CONDITIONER MUST BE OFF TO INSURE  
NORMAL TAKEOFF CLIMB PERFORMANCE.”**

THIS PAGE INTENTIONALLY LEFT BLANK

---

SECTION II  
PROCEDURES

A. SYSTEM OPERATIONS

1. The stall-warning system is inoperative with the master switch off.
2. The electric fuel pump must be on for both landing and takeoff.
3. Some aircraft are equipped with an airspeed - power sensing system (backup gear gear extender ( which extends the landing gear under low airspeed - power conditions\* even though the pilot may not have selected gear down. This system will also prevent retraction of the landing gear by normal means when the airspeed - power values are below a predetermined minimum. (See Item 5, Procedures Section.) To override this system or to hold the emergency gear lever in the override up position without maintaining manual pressure on the emergency gear lever, pull the lever full up and push the latch pin in. To release the override, pull lever up to disengage latch pin, then release lever. For normal operation, the pilot should extend and retract the gear with the gear selector switch located on the instrument panel, just as he would if the backup gear extender system were not installed.

\*Approximately 105 mph IAS at any altitude, power off.

WARNING

Panel light dimmer switch must be off to obtain gear lights full intensity during daytime flying. When aircraft is operated at night and panel light dimmer switch is turned on, gear lights will automatically dim.

4. Landing gear position indication and warning lights:
  - (a) The red gear warning light on the instrument panel and the horn operate simultaneously when:
    - (1) In flight, when the throttle is reduced to where the manifold pressure is approximately 14 inches of mercury or below, and the gear selector switch is not in the down position.
    - (2) On aircraft equipped with the backup gear extender, when the system has lowered the landing gear and the gear selector switch is not in the down position and the throttle is not full open.
    - (3) On the ground, when the master switch is on and the gear selector switch is in the up position.

NOTE

On aircraft which are not equipped with the backup gear extender an additional switch is installed which activates the warning horn and light whenever the flaps are extended beyond the approach position (10°) and the landing gear are not down and locked.

- (b) The three green lights on the instrument panel operate individually as each associated gear is locked in the extended position.

## ARROW

---

- (c) The yellow "In Transit" light on the instrument panel operates whenever any of the three gears is not in either the fully retracted position or the fully extended and locked position.
- (d) On aircraft equipped with the backup gear extender, the yellow "Auto Ext. Off" light immediately below the gear selector switch flashes whenever the emergency gear lever is in the full up position.

### 5. Takeoff considerations:

On aircraft equipped with the backup gear extender, after takeoff, if the gear selector switch is placed in the gear up position before reaching the airspeed at which the system no longer commands gear down\*, the gear will not retract. For obstacle clearance on takeoff and for takeoffs from high altitude airports, the landing gear can be retracted at the pilot's discretion by placing the gear selector switch in the up position and then latching the emergency gear lever in the override up position. If desired, the override up position can be selected and latched before takeoff, and the gear will then retract as soon as the gear selector switch is placed in the up position. In this case, care should be taken not to retract the gear prematurely, or the aircraft could settle back onto the runway. If the override lock is used for takeoff, it should be disengaged as soon as sufficient airspeed and terrain clearance are obtained, to return the gear system to normal operation. For normal operation, the pilot should extend and retract the gear with the gear selector switch located on the instrument panel, as if the backup gear extender were not installed.

\*Approximately 85 mph IAS at sea level to approximately 100 mph IAS at 10,000 ft. with a straight line variation between.

THIS PAGE INTENTIONALLY LEFT BLANK

**ARROW**

---

**THIS PAGE INTENTIONALLY LEFT BLANK**

---

**B. EMERGENCY PROCEDURES****1. Emergency landing gear extension instructions:**

Accomplish the following check prior to initiation of the emergency extension procedures:

- (a) Master Switch - Check On
- (b) Circuit Breakers - Check
- (c) Panel Lights - Off (in daytime)
- (d) Gear Indicator Bulbs - Check

If landing gear does not check down and locked:

- (e) Reduce airspeed below 100 mph.
- (f) Move landing gear selector switch to gear down position.
- (g) If gear has failed to lock down, on aircraft equipped with the backup gear extender, raise emergency gear lever to "Override Engaged" position.
- (h) If gear has still failed to lock down, move emergency gear lever to "Emergency Down" position.
- (i) If gear has still failed to lock down, yaw the airplane abruptly from side to side with the rudder.

If the nose gear will not lock down using the above procedure, slow the aircraft to the lowest safe speed attainable using the lowest power setting required for safe operation and accomplish the following:

- (j) On aircraft equipped with backup gear extender, raise emergency gear lever to "Override Engaged" position.
- (k) Move landing gear selector switch to gear down position.

If landing gear does not check down, recycle gear through up position, and repeat (k).

When the Emergency Landing Gear Extension Procedure is performed for training purposes, the following changes must be made to the procedure in order to prevent the hydraulic pump from activating during the procedure. On aircraft equipped with the backup gear extender, the landing gear selector must be left in the UP position until all gear position indicators are green. On aircraft which do NOT have the backup gear extender a pull type LANDING GEAR PUMP circuit breaker is installed and must be pulled prior to executing the emergency extension procedure. The circuit breaker must be reset after the completion of the procedure to allow normal gear system operation.

**2. Gear up emergency landing:**

In the event a gear up landing is required, proceed as follows:

- (a) On aircraft equipped with the backup gear extender, lock emergency gear lever in "Override Engaged" position before airspeed drops to 115 mph to prevent landing gear from inadvertently free falling.
- (b) Flaps as desired.
- (c) Close throttle and shut off the master and ignition switches.
- (d) Turn the fuel selector valve to OFF.
- (e) Contact surface at minimum possible airspeed.

**NOTE**

With the master switch off, the landing gear cannot be retracted.

THIS PAGE INTENTIONALLY LEFT BLANK

---

**SECTION III**  
**PERFORMANCE**

**A. STALLS**

The following performance figures were obtained during FAA type tests and may be realized under conditions indicated with the airplane and engine in good condition and with average piloting technique. All performance is given for 2650 pounds.

Loss of altitude during stalls varied from 100 to 300 feet, depending on configuration and power.

Stalling speeds, in mph, power off, versus angle of bank (Calibrated airspeed):

Angle of bank	0°	20°	40°	50°	60°
Flaps up (gear down)	71	73	81	88	100
Flaps down (gear down)	64	66	73	80	90

**ARROW**

---

**THIS PAGE INTENTIONALLY LEFT BLANK**

**SECTION IV**  
**OPTIONAL EQUIPMENT**

**NOTE**

THE INFORMATION CONTAINED IN THIS SECTION  
APPLIES WHEN THE RELATED EQUIPMENT IS INSTALLED  
IN THE AIRCRAFT.

- A. Electric Pitch Trim Installation
- B. AutoFlite II Installation
- C. Air Conditioner Installation
- D. Installation of Piper AutoControl III and/or AutoControl IIIB

THIS PAGE INTENTIONALLY LEFT BLANK

---

**A. ELECTRIC PITCH TRIM INSTALLATION**

The following information applies in case of electric trim malfunction:

1. In case of malfunction, disengage electric pitch trim by pushing pitch trim switch on instrument panel to off position.
2. In an emergency, electric pitch trim may be overpowered using manual pitch trim.
3. In cruise configuration, a malfunction can result in a 10° pitch change and 200 ft. altitude variation.
4. In approach configuration, a malfunction can result in a 5° pitch change and 50 ft. altitude loss.

**THIS PAGE INTENTIONALLY LEFT BLANK**

---

**B. AUTOFILTE II INSTALLATION****1. LIMITATIONS**

- a. Autopilot use is prohibited above 200 MPH-CAS
- b. Autopilot "OFF" for takeoff and landing

**2. PROCEDURES****a. Normal Operation**

Refer to the current AutoFlite II Owner's Handbook

**b. Emergency Operation**

- (1) In case of malfunction, press disconnect switch on pilot's control wheel.
- (2) Rocker switch on instrument panel - OFF
- (3) Unit may be overpowered manually at either control wheel.
- (4) An autopilot runaway, with a 3 second delay in the initiation of recovery, while operating in a climb, cruise or descending flight could result in a 50° bank and a 190 foot altitude loss.
- (5) An autopilot runaway, with a 1 second delay in the initiation of recovery, during an approach operation, coupled or uncoupled, could result in a 15° bank and a 40 foot altitude loss.

**3. PERFORMANCE**

The airplane performance remains unchanged.

**C. AIR CONDITIONER INSTALLATION**

**1. LIMITATIONS**

Air Conditioner "OFF" for takeoff and landing.

**2. PROCEDURES**

Prior to takeoff, the air conditioner should be checked for proper operation as follows:

- a. Check aircraft master switch on
- b. Turn the air conditioner control switch to "ON" and the fan switch to one of the operating positions - the "AIR COND DOOR OPEN" warning light will turn on, thereby indicating proper air conditioner condenser door actuation.
- c. Turn the air conditioner control switch to OFF - the "AIR COND DOOR OPEN" warning light will go out, thereby indicating the air conditioner condenser door is in the up position.
- d. If the "AIR COND DOOR OPEN" light does not respond as specified above, an air conditioner system or indicator bulb malfunction is indicated and further investigation should be conducted prior to flight.

The above operational check may be performed during flight if an inflight failure is suspected.

**3. PERFORMANCE**

- a. When the full throttle position is not used or in the event of a malfunction which causes the compressor to operate and the condenser door to remain extended, a decrease in rate of climb of as much as 100 fpm can be expected at all altitudes.
- b. Warning - The air conditioner must be off to insure normal takeoff performance.

**D. INSTALLATION OF PIPER AUTOCONTROL III AND/OR AUTOCONTROL IIIB****1. LIMITATIONS**

- a. Autopilot OFF during takeoff and landing.
- b. Autopilot use prohibited above 200 MPH CAS.

**2. PROCEDURES****a. PREFLIGHT****(1) Roll Section**

- (a) Place Radio Coupler in "Heading" mode and place A/P ON/OFF switch in the "ON" position to engage roll section. Rotate roll command knob Left and Right and observe control wheel describes a corresponding Left and Right turn, then center knob.
- (b) Set proper D.G. Heading on D.G. and turn Heading Indice to aircraft heading. Engage "Heading" mode switch and rotate Heading Indice right and left. Aircraft control wheel should turn same direction as Indice. While D.G. indice is set for a left turn, grasp control wheel and override the servo to the right. Repeat in opposite direction for right turn.
- (c) If VOR signal available check Omni mode on Radio Coupler by swinging Omni needle left and right slowly. Observe that control wheel rotates in direction of needle movement.
- (d) Disengage by placing the A/P ON/OFF switch to the "OFF" position.

**b. IN-FLIGHT****(1) Trim airplane (ball centered).**

(2) Check air pressure or vacuum to ascertain that the Directional Gyro and Attitude Gyro are receiving sufficient air.

**(3) Roll Section**

- (a) To engage, center Roll Command Knob, place the A/P ON/OFF switch to the "ON" position. To turn rotate roll command knob in desired direction. (Maximum angle of bank should not exceed 30°.)
- (b) For heading mode, set Directional Gyro with Magnetic Compass. Push directional gyro HDG knob in, rotate to aircraft heading. Place the console HDG ON/OFF switch to the "ON" position. To select a new aircraft heading, push D.G. heading knob IN and rotate, in desired direction of turn, to the desired heading.

**NOTE**

In HDG mode the maximum bank angles are limited to approximately 20° and single command, heading changes should be limited to 150°. (HDG Indice not more than 150° from actual aircraft heading.)

4) VOR

(a) To Intercept:

1. Using OMNI Bearing Selector, dial desired course, inbound or outbound.
2. Set identical heading on Course Selector D.G.
3. After aircraft has stabilized, position coupler mode selector knob to OMNI mode. As aircraft nears selected radial, interception and crosswind correction will be automatically accomplished without further switching.

NOTE

If aircraft position is less than 45° from selected radial, aircraft will intercept before station. If position is more than 45°, interception will occur after station passage. As the aircraft nears the OMNI station, (1/2 mile) the zone of confusion will direct an "S" turn in alternate directions as the OMNI indicator needle swings. This alternate banking limited to the standard D.C. bank angle, is an indication of station passage.

(b) To select new course:

1. To select a new course or radial, rotate the HDG indice to the desired HDG (match course).
2. Rotate OBS to the new course. Aircraft will automatically turn to the intercept heading for the new course.

(c) To change stations:

1. If same course is desired, merely tune receiver to new station frequency.
2. If different course is desired, position coupler mode selector to HDG mode. Dial course selector D.G. to new course. Dial OBS to new course and position coupler mode selector to OMNI mode.

(5) VOR Approach

Track inbound to station as described in VOR navigation section.

After station passage:

- (a) Dial outbound course on Course Selector D.G., then dial same course on OBS.
- (b) After established on outbound radial, position coupler mode selector to HDG mode and select outbound procedure turn heading. After 40 seconds to 1 minute select a turn in the desired direction with the Course Selector D.G. to the inbound procedure turn heading.
- (c) Set OBS to inbound course.
- (d) When aircraft heading is 45° to the inbound course, dial Course Selector D.G. to inbound course and position coupler mode selector to OMNI mode.

## NOTE

For precise tracking over OMNI station, without "S" turn, position coupler mode selector to HDG mode just prior to station passage. If holding pattern is desired, position coupler mode selector to HDG mode at station passage inbound and select outbound heading in direction of turn. After elapsed time, dial inbound course on Course Selector D.G. When aircraft heading is 45° to radial, position coupler mode selector to OMNI mode.

## (6) LOC Approach Only

- (a) To intercept dial ILS outbound course on Course Selector D.G. When stabilized, position coupler mode selector to LOC REV mode.
- (b) After interception and when beyond outer marker, position coupler mode selector to HDG mode and dial outbound procedure turn heading. After one minute, dial inbound procedure turn heading in direction of turn.
- (c) When aircraft heading is 45° to ILS inbound course dial inbound course on Course Selector D.G. and position coupler mode selector to LOC NORM mode.
- (d) At the missed approach point (M.A.P.), or when missed approach is elected, position coupler mode selector to HDG mode and execute missed approach procedure.

## (7) LOC Approach - Back Course (Reverse)

- (a) To intercept dial ILS Back Course outbound heading on Course Selector D.G. When stabilized, position coupler mode selector to LOC NORM mode.
- (b) After interception and when beyond fix, position coupler mode selector to HDG and dial outbound procedure turn heading. After one minute, dial inbound procedure turn heading in direction of turn.
- (c) When heading 45° to inbound course, dial inbound course on Course Selector D.G. and position coupler mode selector to LOC REV mode.
- (d) Approximately 1/2 mile from runway, position coupler mode selector to HDG mode to prevent "S" turn over ILS station near runway threshold.
- (e) Missed approach - same as Front Course. (See (6) d)

c. EMERGENCY OPERATION

- (1) In an emergency the AutoControl can be disconnected by:
  - (a) Placing the A/P ON/OFF switch to the "OFF" position.
  - (b) Pulling the Autopilot circuit breaker (aircraft S/N 28-7635001 and up).
- (2) The AutoControl can be overpowered at either control wheel.
- (3) An Autopilot runaway, with a 3 second delay in the initiation of recovery, while operating in a climb, cruise or descending flight could result in a 45° bank and 150 foot altitude loss.
- (4) An Autopilot runaway, with a 1 second delay in the initiation of recovery, during an approach operation, coupled or uncoupled, could result in a 15° bank and 50 foot altitude loss.

3. PERFORMANCE

No change.

Garmin International, Inc.  
1200 E. 151<sup>st</sup> Street  
Olathe, Kansas 66062 U.S.A.

FAA APPROVED

AIRPLANE FLIGHT MANUAL SUPPLEMENT  
or  
SUPPLEMENTAL AIRPLANE FLIGHT MANUAL  
for the  
Garmin GTX 33X and GTX 3X5 Transponders with ADS-B  
as installed in

Piper PA 28R-200  
Make and Model Airplane

Registration Number: N6828J Serial Number: 28R-7635337

This document serves as an FAA Approved Airplane Flight Manual Supplement or Supplemental Airplane Flight Manual when the GTX 33X or GTX 3X5 with ADS-B is installed in accordance with Supplemental Type Certificate SA01714WI. This document must be incorporated into the FAA Approved Airplane Flight Manual or provided as an FAA Approved Supplemental Airplane Flight Manual.

The information contained herein supplements the FAA approved Airplane Flight Manual. For limitations, procedures, loading and performance information not contained in this document, refer to the FAA approved Airplane Flight Manual, markings, or placards.

FAA Approved By:

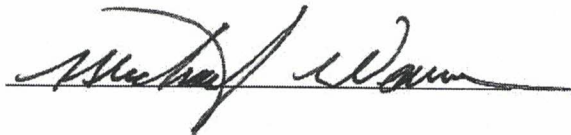

Michael Warren  
ODA STC Unit Administrator  
Garmin International, Inc.  
ODA-240087-CE

Date: 08-MAR-2016



LOG OF REVISIONS				
Revision Number	Page		Description	FAA Approved
	Date	Number		
1	05/01/2013	All	Complete Supplement	<i>Robert Murray</i> Robert Murray ODA STC Unit Administrator Garmin International, Inc. ODA-240087-CE Date: <u>05/01/2013</u>
2	03/08/2016	All	New supplement format with GTX 3X5 added.	See cover page



## Table of Contents

SECTION	PAGE
<b>Section 1. GENERAL</b>	<b>4</b>
1.1 GTX 33X	4
1.2 GTX 3X5	6
1.3 Capabilities	8
1.4 Installation Configuration	9
1.5 Definitions	11
<b>Section 2. LIMITATIONS</b>	<b>12</b>
2.1 Minimum Equipment	12
2.2 ADS-B Out	12
2.3 TIS Traffic Display with User Navigation Angle	12
2.4 Applicable System Software	13
2.5 Pressure Altitude Broadcast Inhibit (PABI)	13
2.6 Datalinked Weather Display (GTX 345 Only)	13
2.7 Portable Electronic Devices	13
<b>Section 3. EMERGENCY PROCEDURES</b>	<b>14</b>
3.1 Emergency Procedures	14
3.2 Abnormal Procedures	14
<b>Section 4. NORMAL PROCEDURES</b>	<b>16</b>
4.1 Unit Power On	16
4.2 Before Takeoff	17
<b>Section 5. PERFORMANCE</b>	<b>17</b>
<b>Section 6. WEIGHT AND BALANCE</b>	<b>17</b>
<b>Section 7. SYSTEM DESCRIPTION</b>	<b>18</b>
7.1 GTX TIS Behavior	18
7.2 GTX 345R and G950/1000 No Bearing Traffic Alerts	18



## Section 1. GENERAL

### 1.1 GTX 33X

The Garmin GTX 33X family consists of the GTX 330 ES and GTX 33 ES (Non-Diversity Mode S Transponders) and the GTX 330D ES and GTX 33D ES (Diversity Mode S Transponders). The ES option of any of the transponders provides ADS-B extended squitter functionality.

All Garmin GTX 33X transponders are a radio transmitter/receiver that operates on radar frequencies, receiving ground radar or TCAS interrogations at 1030 MHz and transmitting a coded response of pulses to ground-based radar on a frequency of 1090 MHz. Each unit is equipped with IDENT capability and will reply to ATCRBS Mode A, Mode C and Mode S All-Call interrogation. Interfaces to the GTX 33X are shown in the following block diagrams.

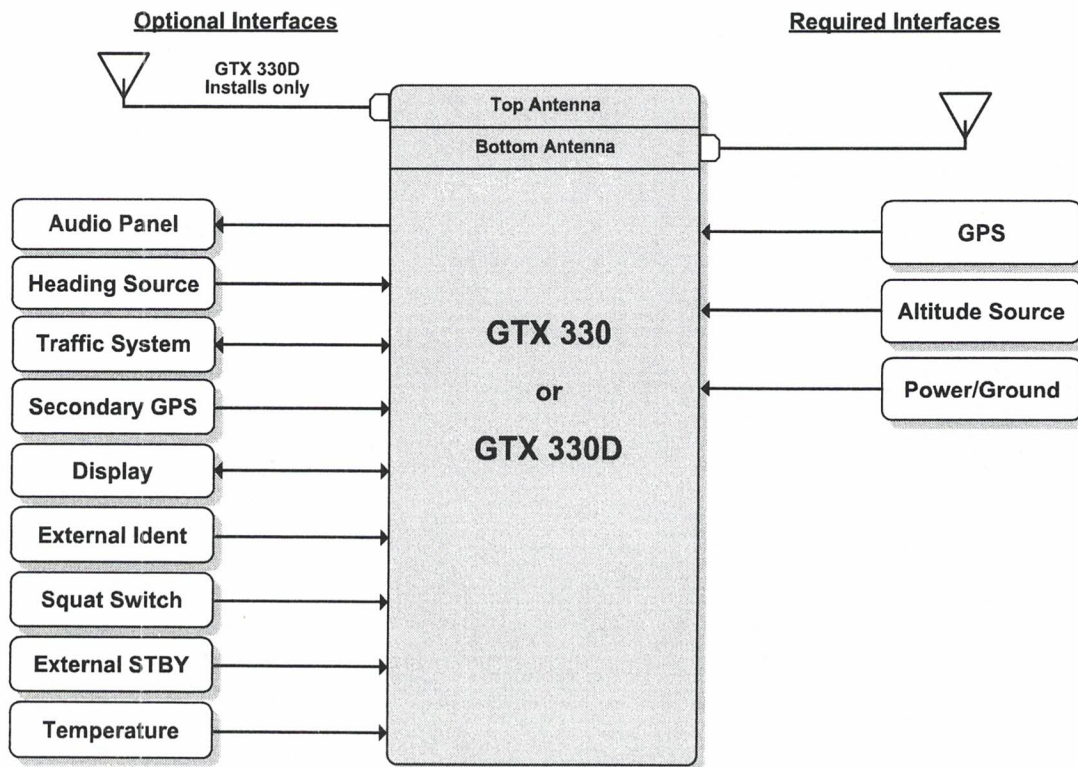
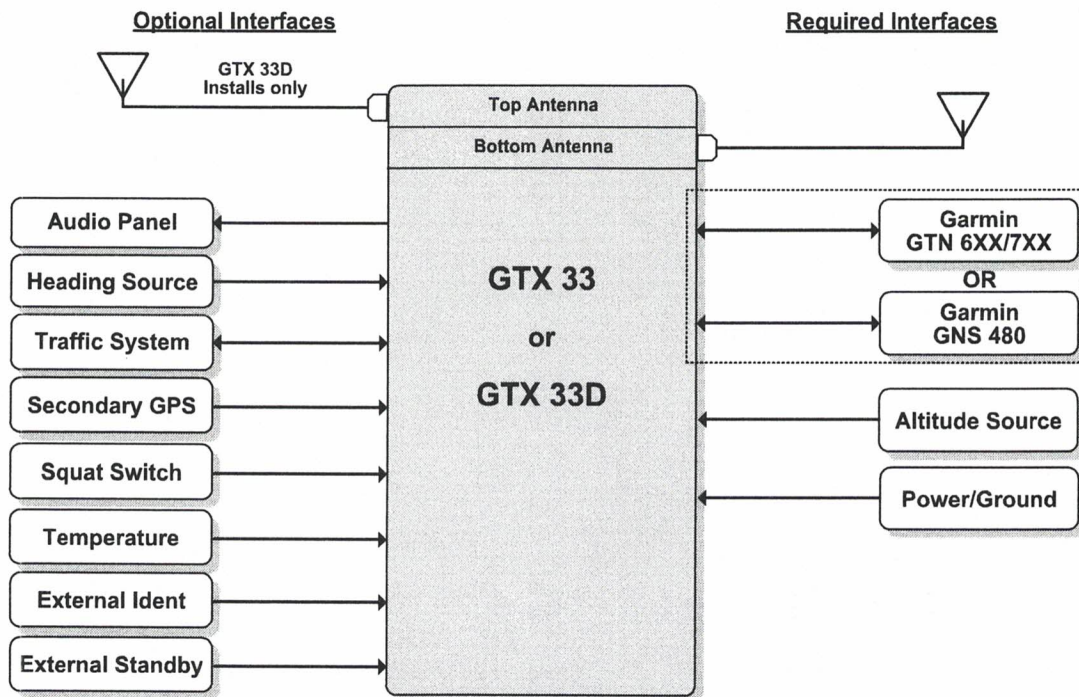

Figure 1 – GTX 330 or GTX 33D Interface Summary





**Figure 2 – GTX 33 or GTX 33D Interface Summary**

The GTX 33X performs the following functions:

- Transmission of ADS-B out data on 1090 extended squitter (1090ES) (1090 MHz)
  - Integration of data from internal and external sources to transmit the following data per 14 CFR 91.227:
    - GPS Position, Altitude, and Position Integrity
    - Ground Track and/or Heading, Ground Speed, and Velocity Integrity
    - Air Ground Status
    - Flight ID, Call Sign, ICAO Registration Number
    - Capability and Status Information
    - Transponder Squawk Code, IDENT, and Emergency Status
  - Pressure Altitude Broadcast Inhibit
- Reception of TIS-A traffic data from a ground station
- Provide TIS-A traffic alerting to the pilot via interfaced display and audio output



## 1.2 GTX 3X5

The Garmin GTX 3X5 family consists of the GTX 335, 335R, 345, and 345R transponders. The functional differences between each of these transponders are described in Table 1.

Function	GTX 335	GTX 335 w GPS	GTX 335R	GTX 335R w GPS	GTX 345	GTX 345 w GPS	GTX 345R	GTX 345R w GPS
Panel mount	x	x			x	x		
Remote mount			x	x			x	x
Mode S	x	x	x	x	x	x	x	x
ADS-B (out)	x	x	x	x	x	x	x	x
ADS-B Traffic					x	x	x	x
FIS-B					x	x	x	x
Internal GPS		x		x		x		x
Bluetooth					x	x	x	x
Optional Garmin Altitude Encoder	x	x	x	x	x	x	x	x

**Table 1 – GTX 3X5 Unit Configurations**

Interfaces to the GTX 3X5 are shown in Figure 3.



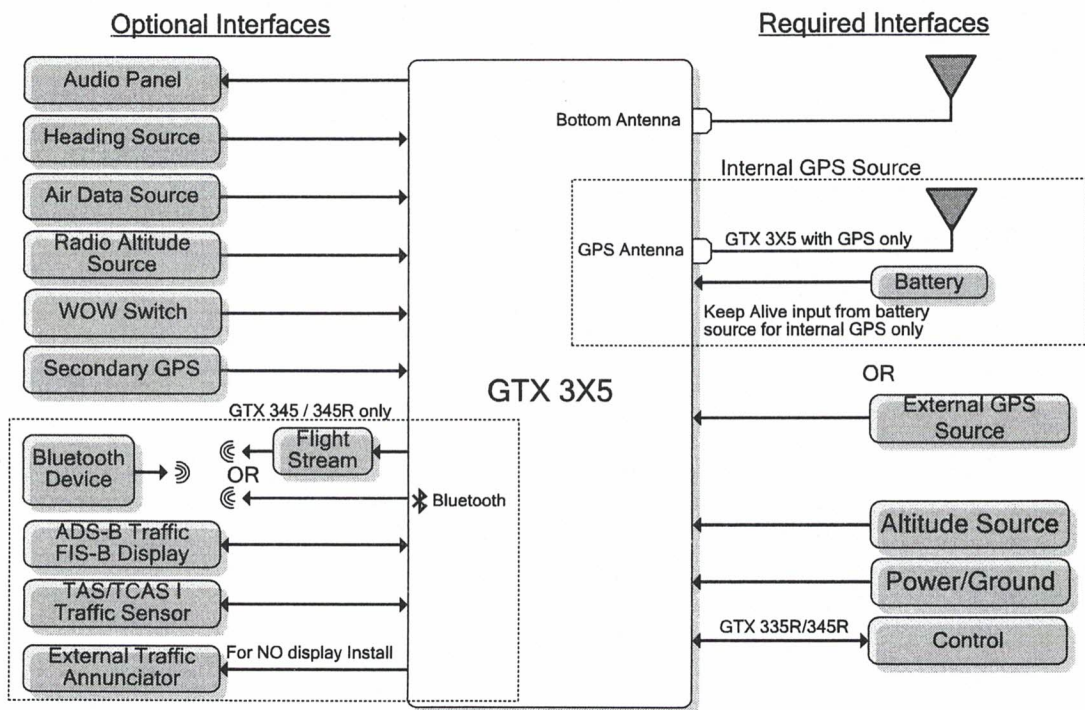

**Figure 3 – GTX 3X5 Interface Summary**

The GTX 3X5 performs the following functions:

- Transmission of ADS-B out data on 1090 extended squitter (1090ES) (1090 MHz)
  - Integration of data from internal and external sources to transmit the following data per 14 CFR 91.227:
    - GPS Position, Altitude, and Position Integrity
    - Ground Track and/or Heading, Ground Speed, and Velocity Integrity
    - Air Ground Status
    - Flight ID, Call Sign, ICAO Registration Number
    - Capability and Status Information
    - Transponder Squawk Code, IDENT, and Emergency Status
  - Pressure Altitude Broadcast Inhibit

The GTX 335 performs the following additional functions:

- Reception of TIS-A traffic data from a ground station
- Provide TIS-A traffic alerting to the pilot via interfaced display and audio output.



The GTX 345 performs the following additional functions:

- Reception of ADS-B In data on 1090 MHz
  - ADS-B (Data directly from another transmitting aircraft)
  - ADS-R (Rebroadcast of ADS-B data from a ground station)
- Reception of ADS-B In data on UAT (978 MHz)
  - ADS-B (Data directly from another transmitting aircraft)
  - ADS-R (Rebroadcast of ADS-B data from a ground station)
  - TIS-B (Broadcast of secondary surveillance radar) (SSR) derived traffic information from a ground station.
  - FIS-B (Broadcast of aviation data from a ground station)
- Provide ADS-B traffic information and alerting to the pilot via an interfaced display
  - Correlation and consolidation of traffic data from multiple traffic sources
  - Aural and visual traffic alerting
- Provide FIS-B data to the pilot via an interfaced display
  - Graphical and textual weather products
    - NEXRAD
    - PIREPs
    - AIRMET/SIGMETs
    - METARs
    - TAFs
    - Winds Aloft
  - Aviation Data
    - TFRs
    - NOTAMs

### **1.3 Capabilities**

The Garmin GTX 33X and GTX 3X5 as installed in this aircraft have been shown to meet the equipment requirements of 14 CFR § 91.227 when operating in accordance with sections 2.1 and 2.2 of this supplement.



## 1.4 Installation Configuration

This aircraft is equipped with a GTX 33X and/or GTX 3X5 with the following interfaces/ features:

### Equipment Installed:

#### Transponder #1

- GTX 330
- GTX 330D
- GTX 33
- GTX 33D
- GTX 335
- GTX 335R
- GTX 345
- GTX 345R

#### Transponder #2 (if installed)

- GTX 330
- GTX 330D
- GTX 33
- GTX 33D
- GTX 335
- GTX 335R
- GTX 345
- GTX 345R

### Interfaced GPS/SBAS Position Source(s):

#### GPS #1

- Internal
- GTN 6XX/7XX Series
- GNS 400W/500W Series
- GNS 480
- GIA 63
- GDL 88 (GTX 330 only)

#### GPS #2 (if installed)

- Internal
- GTN 6XX/7XX Series
- GNS 400W/500W Series
- GNS 480
- GIA 63
- GDL 88 (GTX 330 only)

### Interfaced Pressure Altitude Source:

#### Pressure Altitude Source #1

- AmeriKing AK-350
- Garmin Altitude Encoder

#### Pressure Altitude Source #2 (if installed)

- \_\_\_\_\_
- Garmin Altitude Encoder



**Interfaced Remote Control Display (Required for remotely mounted GTX variants):**

Transponder #1 Remote Control Display

- GTN 6XX/7XX
- GNS 480
- G950/1000 Display

Transponder #2 Remote Control Display (if installed)

- GTN 6XX/7XX
- GNS 480
- G950/1000 Display

**Interfaced Active Traffic System:**

- None
- TCAD
- TAS/TCAS

**NOTE**

If the system includes all of the following components:

- GTX 345R,
- G950/1000 Display, and
- TCAD or TAS/TCAS

Then the aircraft is no longer equipped with a TSO compliant active TCAD, TAS or TCAS system. Any operational requirement to be equipped with such system is no longer met.



## 1.5 Definitions

The following terminology is used within this document:

<b>ADS-B:</b>	Automatic Dependent Surveillance-Broadcast
<b>AFM:</b>	Airplane Flight Manual
<b>AFMS:</b>	Airplane Flight Manual Supplement
<b>ATCRBS:</b>	Air Traffic Control Radar Beacon System
<b>CFR:</b>	Code of Federal Regulations
<b>ES:</b>	Extended Squitter
<b>GNSS:</b>	Global Navigation Satellite System
<b>GNS:</b>	Garmin Navigation System
<b>GPS:</b>	Global Positioning System
<b>GTX:</b>	Garmin Transponder
<b>GTN:</b>	Garmin Touchscreen Navigator
<b>ICAO:</b>	International Civil Aviation Organization
<b>LRU:</b>	Line Replaceable Unit
<b>PABI:</b>	Pressure Altitude Broadcast Inhibit
<b>POH:</b>	Pilot Operating Handbook
<b>SBAS:</b>	Satellite-Based Augmentation System
<b>SW:</b>	Software
<b>TCAS:</b>	Traffic Collision Avoidance System
<b>TIS:</b>	Traffic Information Service
<b>TX:</b>	Transmit



## Section 2. LIMITATIONS

### 2.1 Minimum Equipment

The GTX 33X and GTX 3X5 must have the following system interfaces fully functional in order to be compliant with the requirements for 14 CFR 91.227 ADS-B Out operations:

<b>Interfaced Equipment</b>	<b>Number Installed</b>	<b>Number Required</b>
Uncorrected Pressure Altitude Source	1	1
GPS SBAS Position Source	1 or more	1
Remote Control Display (for remotely mounted transponders)	1 or more	1

**Table 2 – Required Equipment**

### 2.2 ADS-B Out

The GTX 33X and GTX 3X5 only comply with 14 CFR 91.227 for ADS-B Out when all required functions are operational. When the system is not operational, ADS-B Out transmit failure messages will be present on the remote control display interface, or the GTX 330 or GTX 3X5 panel display.

### 2.3 TIS Traffic Display with User Navigation Angle

Display of TIS traffic from a GTX 33/330 or GTX 335 is not permitted with an interfacing display configured for a navigation angle of “user”.



## 2.4 Applicable System Software

This AFMS/AFM is applicable to the software versions shown in Table 3.

The Main GTX software version is displayed on the splash screen during start up for the GTX 330 and GTX 3X5 panel mounted units, and the External LRU or System page on the interfaced remote control display for remotely mounted GTX transponders.

<b>Software Item</b>	<b>Software Version</b> <i>(or later FAA Approved versions for this STC)</i>
GTX 33X Main SW Version	8.02
GTX 3X5 Main SW Version	2.02

**Table 3 - Software Versions**

## 2.5 Pressure Altitude Broadcast Inhibit (PABI)

Pressure Altitude Broadcast Inhibit shall only be enabled when requested by Air Traffic Control while operating within airspace requiring an ADS-B Out compliant transmitter per 14 CFR 91.227. PABI is enabled by selecting the GTX to ON mode.

## 2.6 Datalinked Weather Display (GTX 345 Only)

Do not use datalink weather information for maneuvering in, near, or around areas of hazardous weather. Information provided by datalink weather products may not accurately depict current weather conditions.

Do not use the indicated datalink weather product age to determine the age of the weather information shown by the datalink weather product. Due to time delays inherent in gathering and processing weather data for datalink transmission, the weather information shown by the datalink weather product may be significantly older than the indicated weather product age.

Do not rely solely upon datalink services to provide Temporary Flight Restriction (TFR) or Notice to Airmen (NOTAM) information.

## 2.7 Portable Electronic Devices

This STC does not relieve the operator from complying with the requirements of 91.23 or any other operational regulation regarding portable electronic devices.



**Section 3. EMERGENCY PROCEDURES**

**3.1 Emergency Procedures**

No Change.

**3.2 Abnormal Procedures**

**3.2.1 LOSS OF AIRCRAFT ELECTRICAL POWER GENERATION**

XPDR Circuit Breaker .....**PULL**

Transponder and ADS-B Out functions will no longer be available.

**NOTE**

This guidance is supplementary to any guidance provided in the POH or AFM for the installed aircraft for loss of power generation.

**3.2.2 LOSS OF GPS/SBAS POSITION DATA**

When the GPS/SBAS receiver is inoperative or GPS position information is not available or invalid, the GTX will no longer be transmitting ADS-B Out data.

For GTX 330 installations:

**NO ADSB annunciator illuminated:**

Interfaced GPS position sources ..... **VERIFY VALID POSITION**

For GTX 3X5 installations:

**NO 1090ES TX annunciator illuminated:**

Interfaced GPS position sources ..... **VERIFY VALID POSITION**

For GTX 33 and GTX 3X5R installations:

**Reference Display Device documentation for applicable annunciation:**

Interfaced GPS position sources ..... **VERIFY VALID POSITION**



### **3.2.3 Dual GTX 3X5R Transponders in a G950/1000 installation**

If Transponder #1 fails and Transponder #2 is activated by the pilot, the G1000 display will provide nuisance alerts unless power is removed from Transponder #1.

#### **Transponder #1 Failed, Transponder #2 Active**

Transponder #1 Circuit Breaker ..... **PULL**



## Section 4. NORMAL PROCEDURES

The procedures described below are specific only to the panel mounted GTX 330 or GTX 3X5 transponders. Cockpit Reference Guides and Pilot Guides for interfaced remote control displays will provide additional operating information specific to the displays or other traffic systems.

ADS-B Out functionality resides within the GTX transponders thereby providing a single point of entry for Mode 3/A code, Flight ID, IDENT functionality and activating or deactivating emergency status for both transponder and ADS-B Out functions. Details on performing these procedures are located in the GTX 330/330D Pilot's Guide and GTX 3X5 Series Transponder Pilot's Guide.

### 4.1 Unit Power On

For GTX 330 installations:

GTX Mode ..... **VERIFY ALT**  
NO ADSB ..... **CONSIDERED**

For GTX 3X5 installations:

GTX Mode ..... **VERIFY ALT**  
NO 1090ES TX ..... **CONSIDERED**

#### NOTE

The NO ADS-B or NO 1090ES TX Annunciation (or associated display annunciations) may illuminate as the unit powers on and begins to receive input from external systems, to include the SBAS position source.



## 4.2 Before Takeoff

### For GTX 330 installations:

ADS-B TX..... **VERIFY ON**  
NO ADSB..... **EXTINGUISHED**

### For GTX 3X5 installations:

1090ES TX CTL..... **VERIFY ON**  
NO 1090ES TX ..... **EXTINGUISHED**

### NOTE

The ADS-B TX or 1090ES TX CTL must be turned on and the NO ADS-B or NO 1090ES TX Annunciation (or associated display annunciations) must be **EXTINGUISHED** for the system to meet the requirements specified in 14 CFR 91.227. This system must be operational in certain airspaces after January 1, 2020 as specified by 14 CFR 91.225.

## Section 5. PERFORMANCE

No change.

## Section 6. WEIGHT AND BALANCE

See current weight and balance data.



## Section 7. SYSTEM DESCRIPTION

The Garmin GTX 330 and GTX 3X5 Pilot's Guides, part numbers, and revisions listed below contain additional information regarding GTX system description, control, and function.

<u>Title</u>	<u>Part Number</u>	<u>Revision</u>
GTX 330 Pilot's Guide	190-00207-00	Rev. G (or later)
GTX 3X5 Pilot's Guide	190-01499-00	Rev. A (or later)

Pilot's Guides for interfaced displays, part numbers and revisions listed below, provide additional operating information for the Garmin GTX 33 and GTX 3X5R.

<u>Title</u>	<u>Part Number</u>	<u>Revision</u>
Garmin GTN 725/750 Pilot's Guide	190-01007-03	Rev. E (or later)
Garmin GTN 625/635/650 Pilot's Guide	190-01004-03	Rev. E (or later)
GNS 480 Pilot's Guide	190-00502-00	Rev. D (or later)
GTX 3X5 Series Transponder G1000 Pilot's Guide	190-01499-01	Rev. A (or later)

### 7.1 GTX TIS Behavior

The TIS Standby/Operate controls for GTX 33/330 and GTX 335 units only function when the aircraft is airborne.

### 7.2 GTX 345R and G950/1000 No Bearing Traffic Alerts

No visual indication is provided for no bearing traffic alerts. Only an aural indication of the no bearing traffic alert is provided. If an aural alert for no bearing traffic has been previously issued, a "no bearing traffic clear" aural indication will be provided once all traffic alerts are resolved.

All aural alerts are inhibited below 500' AGL, therefore a "no bearing traffic clear" aural may not be heard in a landing or touch and go flight scenario.



# EMERGENCY PROCEDURE

Introduction .....	4-1
Engine Fire During Start.....	4-2
Engine Power Loss During Take-Off .....	4-2
Engine Power Loss In Flight .....	4-3
Power Off Landing .....	4-3
Gear Down Landing .....	4-4
Gear Up Landing .....	4-5
Propeller Overspeed .....	4-5
Emergency Landing Gear Extension.....	4-5
Spins .....	4-6
Open Door .....	4-6
Fire.....	4-7
Loss of Oil Pressure.....	4-7
Loss of Fuel Pressure.....	4-8
High Oil Temperature.....	4-8
Alternator Failure .....	4-8

BLANK PAGE

RESEARCH PROCEDURE

Faint, illegible text, possibly bleed-through from the reverse side of the page.

## EMERGENCY PROCEDURES

### INTRODUCTION

This section contains procedures that are recommended if an emergency condition should occur during ground operation, take-off, or in-flight. These procedures are suggested as the best course of action for coping with the particular condition described, but are not a substitute for sound judgment and common sense. Since emergencies rarely happen in modern aircraft, their occurrence is usually unexpected, and the best corrective action may not always be obvious. Pilots should familiarize themselves with the procedures given in this section and be prepared to take appropriate action should an emergency arise.

Most basic emergency procedures, such as power off landings, are a part of normal pilot training. Although these emergencies are discussed here, this information is not intended to replace such training, but only to provide a source of reference and review, and to provide information on procedures which are not the same for all aircraft. It is suggested that the pilot review standard emergency procedures periodically to remain proficient in them.

In the procedures that follow, critical actions with respect to time are indicated by use of bold print; these actions should be performed immediately if the emergency condition is not to be aggravated. The remaining procedures are non-critical in the sense that time is usually available for consulting the check list.

## ARROW II

---

### ENGINE FIRE DURING START

Refer to FIRE emergency procedures.

### ENGINE POWER LOSS DURING TAKE-OFF

The proper action to be taken if loss of power occurs during take-off will depend on circumstances.

1. If sufficient runway remains for a normal landing, leave the gear down and land straight ahead.
2. If the area ahead is rough, or if it is necessary to clear obstructions, put gear selector switch in the UP position. On aircraft equipped with the backup gear extender, latch the gear lever in the override position.
3. If you have gained sufficient altitude to attempt a restart, proceed as follows:
  - a. MAINTAIN SAFE AIRSPEED
  - b. FUEL SELECTOR - SWITCH TO ANOTHER TANK CONTAINING FUEL
  - c. ELECTRIC FUEL PUMP - CHECK ON
  - d. MIXTURE - CHECK RICH
  - e. ALTERNATE AIR - ON
  - f. EMERGENCY GEAR LEVER - AS REQUIRED

#### NOTE

On aircraft equipped with the backup gear extender, the landing gear will extend automatically when engine power fails at speeds below approximately 105 mph IAS. Glide distance with the gear extended is roughly halved; if conditions dictate, the gear can be retained in the retracted position by latching the lever in the override up position.

#### NOTE

If engine failure was caused by fuel exhaustion, power will not be regained after tanks are switched until empty fuel lines are filled, which may require up to ten seconds.

If power is not regained, proceed with the POWER OFF LANDING procedure.

---

## ENGINE POWER LOSS IN FLIGHT

Complete engine power loss is usually caused by fuel flow interruption, and power will be restored shortly after fuel flow is restored. If power loss occurs at low altitude, the first step is to prepare for an emergency landing (See POWER OFF LANDING). Maintain an airspeed of at least 110 MPH IAS, gear and flaps up and if altitude permits proceed as follows:

1. Fuel Selector - Switch to another tank containing fuel.
2. Electric Fuel Pump - On
3. Mixture - Rich
4. Alternate Air - On
5. Engine Gauges - Check for indication of the cause of power loss.
6. If no fuel pressure is indicated, check tank selector position to be sure it is on a tank containing fuel.

When power is restored:

7. Alternate Air - Off
8. Electric Fuel Pump - Off

If the above steps do not restore power, prepare for an emergency landing. If time permits:

1. Ignition Switch - "L" then "R" then back to "BOTH."
2. Throttle and Mixture - Different settings. (This may restore power if problem is too rich or too lean a mixture, or partial fuel system restriction.)
3. Try another fuel tank. (Water in the fuel could take some time to be used up, and allowing the engine to windmill may restore power. If power loss is due to water, fuel pressure indications will be normal).

### NOTE

If engine failure was caused by fuel exhaustion, power will not be restored after tanks are switched until empty fuel lines are filled, which may require up to ten seconds.

If power is not restored, proceed with POWER OFF LANDING procedures.

## POWER OFF LANDING

If loss of power occurs at altitude, trim the aircraft for best gliding angle (105 MPH IAS) (Air Cond. off) and look for a suitable field. (See Note) If measures taken to restore power are not effective, and if time permits, check your charts for airports in the immediate vicinity; it may be possible to land at one if you have sufficient altitude. At best gliding angle, with the engine windmilling, and the propeller control in full "decrease RPM," the aircraft will travel approximately 1.6 miles for each thousand feet of altitude. If possible, notify the FAA by radio of your difficulty and intentions. If another pilot or passenger is aboard, let him help.

When you have located a suitable field, establish a spiral pattern around this field. Try to be at 1000 feet above the field at the downwind position, to make a normal landing approach. When the field can easily be reached, slow to 90 MPH IAS for the shortest landing. Excess altitude may be lost by widening your pattern, using flaps or slipping, or a combination of these.

## ARROW II

---

Whether to attempt a landing with gear up or down depends on many factors. If the field chosen is obviously smooth and firm, and long enough to bring the plane to a stop, the gear should be down. If there are stumps or rocks or other large obstacles in the field, the gear in the down position will better protect the occupants of the aircraft. If, however, the field is suspected to be excessively soft or short, or when landing in water of any depth, a wheels-up landing will normally be safer and do less damage to the airplane.

On aircraft equipped with the backup gear extender at airspeeds below approximately 105 mph IAS the gear will free fall, and will take six to eight seconds to free fall and lock. If a gear up landing is desired, it will be necessary to latch the override lever in the up position before airspeed drops to 115 mph to prevent landing gear from inadvertently free falling.

Touchdown should normally be made at the lowest possible airspeed.

### GEAR DOWN LANDING

For a gear down landing, proceed as follows when committed to landing:

1. Gear selector switch - down
2. Close throttle and shut off the master and ignition switches
3. Flaps as desired
4. Turn the fuel selector valve to off
5. Mixture - Idle cut-off
6. Tighten seat belt (and shoulder harness, if available)
7. Touchdown at lowest possible airspeed

#### NOTE

On aircraft equipped with the backup gear extender, the mechanism will extend the gear below approximately 105 mph IAS with power off. Be prepared to latch the emergency override lever UP before airspeed drops to 115 mph to prevent landing gear from inadvertently free falling, until gear extension is desired.

#### NOTE

With the master switch off, the landing gear cannot be retracted.

### GEAR UP LANDING

In the event a gear up landing is desired, proceed as follows when committed to landing:

1. On aircraft equipped with the backup gear extender, lock emergency gear lever in "Override Engaged" position before airspeed drops to 115 mph to prevent landing gear from inadvertently free falling.
2. Flaps as desired.
3. Close throttle and shut off the master and ignition switches.
4. Turn the fuel selector valve to off.
5. Tighten seat belt (and shoulder harness, if available).
6. Contact surface at minimum possible airspeed.

#### NOTE

With the master switch off, the landing gear cannot be retracted.

---

### PROPELLER OVERSPEED

Propeller overspeed is caused by a malfunction in the propeller governor, or low oil pressure, which allows the propeller blades to rotate to full low pitch. If this should occur, proceed as follows:

1. THROTTLE - RETARD.
2. OIL PRESSURE - CHECK.
3. PROPELLER CONTROL - FULL RECREASE RPM, THEN SET IF ANY CONTROL AVAILABLE.
4. REDUCE AIRSPEED.
5. THROTTLE - AS REQUIRED TO REMAIN BELOW 2700 RPM.

### EMERGENCY LANDING GEAR EXTENSION

Accomplish the following checks prior to initiation of the emergency extension procedure:

1. Master Switch - Check On.
2. Circuit Breakers - Check.
3. Panel Lights - Off (in daytime).
4. Gear Indicator Bulbs - Check.

If landing gear does not check down and locked:

5. Reduce airspeed below 100 mph.
6. Move landing gear selector switch to gear down position.
7. If gear has failed to lock down, on aircraft equipped with the backup gear extender, raise emergency gear lever to "Override Engaged" position.
8. If gear has still failed to lock down, move emergency gear lever to Emergency Down position.
9. If gear has still failed to lock down, yaw the airplane abruptly from side to side with the rudder.

#### NOTE

If all electrical power has been lost, the landing gear must be extended using the above emergency procedures. The landing gear position indicator lights will not be operative.

#### NOTE

Refer to page 3-11 for differences when emergency extension procedure is performed for training purposes.

## ARROW II

---

### SPINS

Intentional spins are prohibited in this aircraft. If a spin is inadvertently entered, immediately use the following recovery procedures:

1. THROTTLE - IDLE.
2. RUDDER - FULL OPPOSITE TO DIRECTION OF ROTATION.
3. CONTROL WHEEL - FULL FORWARD.
4. RUDDER - NEUTRAL (WHEN ROTATION STOPS).
5. CONTROL WHEEL - AS REQUIRED TO SMOOTHLY REGAIN LEVEL FLIGHT ATTITUDE.

### NOTE

On aircraft equipped with the backup gear extender, the landing gear will extend in this flight condition, but will retract during recovery, and has no adverse affect on the spin characteristics.

### OPEN DOOR

The cabin door on the Cherokee Arrow II is latched at four points so the chances of its opening in flight are remote. However, should you forget to completely close or latch the door, it may open partially. This will usually happen soon after take-off. An open door will not affect the normal flight characteristics, and a normal landing can be made with it open. If the door opens it will trail in a slightly open position, and the airspeed will be reduced slightly.

To close the door in flight, proceed as follows:

1. Slow aircraft to 100 mph IAS.
2. Cabin Vents - Close.
3. Storm Window - Open.
4. If upper latch is open - latch. If lower latch is open - open top latch, push door further open, and then close rapidly. Latch top latch.

A slip in the direction of the open door will assist in latching procedure.

## FIRE

The presence of fire is noted through smoke, smell, and heat in the cabin. It is essential that the source of the fire be promptly identified through instrument readings, character of the smoke, or other indications, since the action to be taken differs somewhat in each case.

1. Source of Fire - Check
  - a. Electrical Fire (Smoke in Cabin):
    - (1) Master Switch - Off
    - (2) Vents - Open
    - (3) Cabin Heat - Off
    - (4) Land as soon as practicable.
  - b. Engine Fire:
    - (1) In case of engine fire in flight
      - (a) Fuel Selector - OFF
      - (b) Throttle - CLOSE
      - (c) Mixture - IDLE CUT OFF
      - (d) Heater - Off (In all cases of fire)
      - (e) Defroster - OFF (In all cases of fire)
      - (f) If terrain permits - Land Immediately

The possibility of an engine fire in flight is extremely remote. The procedure given above is general and pilot judgement should be the deciding factor for action in such an emergency.

- (2) In case of engine fire on the ground
  - (a) If engine has not started
    1. Mixture - IDLE CUT OFF
    2. Throttle - OPEN
    3. Turn engine with starter (This is an attempt to pull the fire into the engine.)
  - (b) If engine has already started and is running, continue operating to try pulling the fire into the engine.
  - (c) In either case stated in (a) and (b), if the fire continues longer than a few seconds, the fire should be extinguished by the best available external means.
  - (d) If external fire extinguishing is to be applied
    1. Fuel Selector Valves - OFF
    2. Mixture - IDLE CUT OFF

## LOSS OF OIL PRESSURE

Loss of oil pressure may be either partial or complete. A partial loss of oil pressure usually indicates a malfunction in the oil pressure regulating system, and a landing should be made as soon as possible to investigate the cause and prevent engine damage.

A complete loss of oil pressure indication may signify oil exhaustion or may be the result of a faulty gauge. In either case, proceed toward the nearest airport, and be prepared for a forced landing. If the problem is not a pressure gauge malfunction, the engine may stop suddenly. Maintain altitude until such time as a dead stick landing can be accomplished. Don't

## ARROW II

---

change power settings unnecessarily, as this may hasten complete power loss.

Depending on the circumstances, it may be advisable to make an off airport landing while power is still available, particularly if other indications of actual oil pressure loss, such as sudden increase in temperatures, or oil smoke, are apparent, and an airport is not close.

If engine stoppage occurs, proceed to POWER OFF LANDING.

### LOSS OF FUEL PRESSURE

1. Electric Boost Pump - On.
2. Mixture Control Forward.
3. Fuel Selector - Check on full tank.

If problem is not an empty fuel tank, land as soon as practicable and have the fuel system checked.

### HIGH OIL TEMPERATURE

An abnormally high oil temperature indication may be caused by a low oil level, an obstruction in the oil cooler, damaged or improper baffle seals, a defective gauge, or other causes. Land as soon as practicable at an appropriate airport, and have the cause investigated.

A steady, rapid rise in oil temperature is a sign of trouble. Land at the nearest airport and let a mechanic investigate the problem. Watch the oil pressure gauge for an accompanying loss of pressure.

### ALTERNATOR FAILURE

Loss of alternator output is detected through a zero reading on the ammeter. Before executing the following procedure, insure that the reading is zero and not merely low by actuating an electrically powered device, such as the landing light. If no increase in the ammeter reading is noted, alternator failure can be assumed.

1. Reduce electrical load.
2. Alternator Circuit Breakers - Check.
3. "Alt" Switch - Off (for 1 second), then On.

If the ammeter continues to indicate no output, or alternator will not stay reset, turn off "Alt" switch, maintain minimum electrical load, and land as soon as practical. All electrical power is being supplied by the battery.

#### NOTE

If the battery is fully discharged, the gear will have to be lowered using the "EMERGENCY LANDING GEAR EXTENSION" procedure, and the position lights will of course not be operating.

Tdata, Inc.

Tail #: **N6828J**  
 Serial #: **28R-7635337**  
 Make: **Piper**  
 Model: **PA28R-200**  
 TCDS #: **2A13**  
 U.L.: **978.50**  
 E.W.: **1671.50**  
 E.W.C.G.: **84.43**  
 MOMENT: **141129.76**

**WEIGHT & BALANCE REVISION**

Owner (s): **Kirk Shireman**  
 Address: **1617 Inverness Lane  
 Pearland, Texas 77581**

Date: **7/10/2018**  
 W.O.#: **13676**  
 Prev. W & B on: **10/31/17**  
 Max. Weight: **2650.00**  
 FLT. C.G. **FWD** **AFT**  
 RANGE: **87.3** **93**  
 MOMENT: **141129.76**

NOTE: THE NEW  
 E.W. C.G. IS OUTSIDE THE  
 LISTED FLIGHT C.G ENVELOPE.  
 + VERIFY OK PER TCDS +

NEW USEFUL LOAD: **986.04**  
 NEW EMPTY WEIGHT: **1663.96**  
 NEW EMPTY WEIGHT C.G.: **84.55**  
 NEW MOMENT: **140683.37**

ITEMS REMOVED	SERIAL NUMBER	WEIGHT (- LB)	ARM* (+ -)	MOMENT (IN-LBS)	ITEMS INSTALLED	SERIAL NUMBER	WEIGHT (+ LB)	ARM* (+ -)	MOMENT (IN-LBS)
Vacuum Pump		-3.20	29.60	-94.72	Garmin G5 PFD	011-03809	0.98	18.00	17.64
Vacuum Regulator		-0.60	52.00	-31.20	Garmin G5 HSI	011-03809	0.98	18.00	17.64
Suction Gauge		-0.50	62.20	-31.10	Garmin GAD29B	010-01172-11	0.80	8.00	6.40
Vacuum filter		-0.30	15.50	-4.65	Garmin GMU11	011-04349-01			
Attitude Gyro		-2.20	59.40	-130.68					
Directional Gyro		-2.60	59.70	-155.22					
Standby Vacuum		-0.90	45.00	-40.50					
<b>TOTAL REMOVED EQUIPMENT</b>		<b>-10.30</b>	<b>47.39</b>	<b>-488.07</b>	<b>TOTAL INSTALLED EQUIPMENT</b>		<b>2.76</b>	<b>15.10</b>	<b>41.68</b>

Prepared by: **Kirk Taylor** Signature: *[Signature]* Date: **7/10/2018**

Approved by: \_\_\_\_\_ Signature: \_\_\_\_\_ Date: \_\_\_\_\_

\*TO ENTER A "0" VALUE IN "ARM" ENTER .0001

Notes:

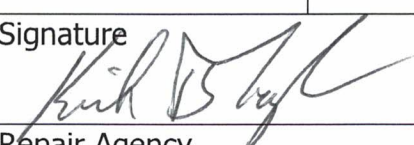

## Aircraft Weight and Balance Revision

Tail Number: <b>N6828J</b>		Date: Oct 31, 2017	
Prepared by: Total Aircraft Services, Inc 17910 Airfield Lane Pearland Texas 77581		Work Order No: 13503	
		Type Certificate Data No: 2A13	
Aircraft Make: Piper	Model: PA-28R-200	Serial No: 28R-7635337	Time: 4438.46
Registered Owner: Kirk A Shireman		Address: 1617 Inverness Lane Pearland Texas, 77581-5911	
Maximum Weight <b>2650</b>		CG Range FWD <b>87.3</b> AFT <b>93</b>	
As Received; Date of Previous Weight and Balance: 9/30/02	<b>Useful Load:</b> 979	<b>EW:</b> 1671	<b>EWCG:</b> 84.4
<b>Moment:</b> 141032.3			
Notes:			
		<b>Weight</b>	<b>Arm</b>
		<b>Moment</b>	
REMOVED		0.00	0.00
Right Magneto		-6	30
INSTALLED		0.00	0.00
EA-1000 Controller		+8	57
EA-2000 Coil Pack		+2.9	41
EA-3000 Mag Timing Housing		+1.5	35
EA-4000 Spark Plug Wires		+1.1	26
EA-5000 Map Sensor		+4	57
EA-6000 Controller Wire Harness		+8	47
Mag harness		-1	26
<input checked="" type="checkbox"/> As Calculated <input type="checkbox"/> As Weighed		Moment <span style="float: right;">141132.30</span> <hr/> Weight <span style="float: right;">1671.50</span>	<b>New Empty Weight CG</b>  <b>84.43</b>
		<b>New Useful Load</b>  <b>978.50</b>	
Signature 			
Repair Agency or License No:			



# Kansas City Aviation Center

## Additional Equipment list \ Revised weight and balance



P.O Box 1850  
 Olathe, Ks. 66063-1850  
 (913)-782-0530

**N6828J**  
**S/N 28R-7635337**  
**Date Computed 9/30/02**

**EMPTY WEIGHT CALCULATIONS**

**OLD EMPTY WEIGHT CONFIGURATION:**

DATED: 6-12-01

**EMPTY WEIGHT**

Removed Prop  
 Removed Spinner

Installed Prop  
 Installed Spinner

**NEW EMPTY WEIGHT & EMPTY WT C.G.**

LONGITUDINAL		
WEIGHT	ARM	MOMENT
1659.3	85.0	141055.9
<del>1659.3</del>	<del>85.0</del>	<del>141055.9</del>
-55.0	-1.9	104.5
-5.0	-2.2	11.0
67.4	-1.90	-128.1
5.0	-2.20	-11.0
1671.7	84.4	141032.3

The C.G. computations contained herein are representative of the loading configurations contained in the aircraft maintenance manual. It shall be the pilots responsibility to ensure that the aircraft is properly loaded so that the entire flight is conducted within the Gross Weight Center of Gravity Chart in the Limitations Section of the Flight Manual.

*[Handwritten Signature]*  
 \_\_\_\_\_  
**Kansas City Aviation Center, Inc. FAA CRS AMYR171C**



# WEIGHT AND BALANCE

FOR

# CHEROKEE ARROW

## WARNING

EXTREME CARE MUST BE EXERCISED TO LIMIT THE USE OF THIS REPORT TO APPLICABLE AIRCRAFT. THIS REPORT REVISED AS INDICATED BELOW OR SUBSEQUENTLY REVISED IS VALID FOR USE WITH THE AIRPLANE IDENTIFIED BELOW WHEN APPROVED BY PIPER AIRCRAFT CORPORATION. SUBSEQUENT REVISIONS SUPPLIED BY PIPER AIRCRAFT CORPORATION MUST BE PROPERLY INSERTED.

MODEL PA-28R-200

AIRCRAFT SERIAL NO. 28R-35337 REGISTRATION NO. N6828J

WEIGHT AND BALANCE, REPORT NUMBER VB-549 REVISION \_\_\_\_\_

PIPER AIRCRAFT CORPORATION  
APPROVAL SIGNATURE AND STAMP \_\_\_\_\_

ISSUED: MAY 14, 1973  
REVISED: MARCH 25, 1974

REPORT: VB-549  
MODEL: PA-28R-200



# WEIGHT AND BALANCE

Log of Revisions.....	5-iii
Weight and Balance .....	5-1
Weight and Balance Data - Weighing Procedure .....	5-3
Weight and Balance Data .....	5-7
C. G. Range and Weight Instructions .....	5-8
Equipment List .....	5-11



---

**INDEX - WEIGHT AND BALANCE**

Log of Revisions .....	5-iii
Weight and Balance .....	5-1
Weight and Balance Data - Weighing Procedure .....	5-3
Weight and Balance Data .....	5-7
C. G. Range and Weight Instructions .....	5-8
Equipment List .....	5-11
A. Propellers and Propeller Accessories .....	5-11
B. Engine and Engine Accessories - Fuel and Oil Systems .....	5-12
C. Landing Gear and Brakes .....	5-13
D. Electrical Equipment .....	5-14
E. Instruments .....	5-15
F. Hydraulic Equipment .....	5-17
G. Miscellaneous .....	5-18
H. Engine and Engine Accessories - Fuel and Oil System (Optional Equipment) .....	5-20
I. Electrical Equipment (Optional Equipment) .....	5-21
J. Autopilots (Optional Equipment) .....	5-23
K. Radio Equipment (Optional Equipment) .....	5-25
L. Instruments (Optional Equipment) .....	5-29
M. Miscellaneous (Optional Equipment) .....	5-31





## WEIGHT AND BALANCE LOG OF REVISIONS (cont)

Revision	Revised Pages	Description and Revision	Approved Date
3 (cont)	5-28c 5-28d 5-29 5-31  5-32	Added page. Added page. Added Encoding Altimeter. Revised Inertia Safety Belts' Weights, Arm, Moment and Part No.; revised Assist Strap and Coat Hook (62353-5); relocated info to page 5-32. Added info from page 5-31.	
4	5-12 5-14 5-18 5-21 5-29 5-30  5-31  5-32	Deleted Alternator. Revised Battery description. Added 79337-3 Right Front Seat. Revised Rotating Beacon description. Deleted Vacuum Regulator. Added Engine Hour Meter, Radar Altimeter and NSD Gyro; added footnote. Added 79337-18 Front Headrest; added 79337-18 Rear Headrest; added 79591-0 Left Front Seat; relocated Right Front Seat to page 5-32. Added Right Front Seat from page 5-31; added 79591-1 Right Front Seat; added 76304-11 and -12 Overhead Vent Systems; added Stainless Steel Control Cables; added footnote.	June 27, 1975 <i>C.E. Riehl</i>
5	5-22  5-27  5-28  5-29 5-30	Revised Electric Trim System to Piper Pitch Trim 67469-2; added Piper Pitch Trim 67469-3; added footnote. Added King KN61 DME and King KN65A DME. Added Dwg. No. to PAL Transmitter; added PAL Transmitter 79265-6. Deleted Dwg. No. from Clock. Added Narco OC-110 Converter and Mount.	Dec. 8, 1975 <i>George Torgley</i>
6	5-28	Added PAL Transmitter 79761-4.	July 22, 1976 <i>George Torgley</i>

## WEIGHT AND BALANCE LOG OF REVISIONS (cont)

Revision	Revised Pages	Description and Revision	Approved Date
7	5-11	Added McCauley Propeller and Spinner; added footnotes.	<i>Jay Chyng</i>  Feb. 28, 1977
	5-12	Added Lycoming IO-360-C1C6 Engine and footnotes.	
	5-15	Added Tachometer and footnotes.	
	5-29	Revised Attitude and Directional Gyro dash nos.	
8	5-1	Revised Weight and Balance info.	<i>Hal Fletcher</i> April 13, 1979
	5-3	Added Caution; relocated para. 2.6 to pg. 5-4.	
	5-4	Added para. 2.b. from pg. 5-3.	
9	5-1	Revised Weight and Balance info.	<i>Ward Evans</i> Feb. 29, 1984
	5-3	Revised weighing procedures para.	
	5-7	Revised info.	

ISSUED: FEBRUARY 28, 1977  
 REVISED: FEBRUARY 29, 1984

REPORT: VB-549 PAGE 5-v  
 MODEL: PA-28R-200

THIS PAGE INTENTIONALLY LEFT BLANK

## WEIGHT AND BALANCE

In order to achieve the performance and flying characteristics which are designed into the aircraft, the Arrow must be flown with the weight and center of gravity (C.G.) position within the approved envelope. The aircraft offers flexibility of loading. However, you cannot fill the aircraft, with four adults, full fuel tanks and maximum baggage. With the flexibility comes responsibility. The pilot must insure that the airplane is loaded within the loading envelope before he makes a takeoff.

Misloading carries consequences for any aircraft. An overloaded airplane will not take off, climb or cruise as well as when it is properly loaded. The heavier the airplane is loaded the less climb performance it will have.

Center of gravity is a determining factor in flight characteristics. If the C.G. is too far forward in any airplane, it may be difficult to rotate for takeoff or landing. If the C.G. is too far aft, the airplane may rotate prematurely on takeoff or try to pitch up during climb. Longitudinal stability will be reduced. This can lead to inadvertent stalls and even spins; and spin recovery becomes more difficult as the center of gravity moves aft of the approved limit.

A properly loaded aircraft, however, will perform as intended. Before the aircraft is licensed, the Arrow is weighed and a licensed empty weight and C.G. location computed. Using the licensed empty weight and C.G. location, the pilot can easily determine the weight and C.G. position for the loaded airplane by computing the total weight and moment and then determining whether they are within the approved envelope.

The licensed empty weight and C.G. location for a particular airplane are recorded in the weight and balance section of the Airplane Flight Manual. The current values should always be used. Whenever new equipment is added or any modification work is done, the mechanic responsible for the work is required to compute a new basic empty weight and C.G. position and to write these in the aircraft log book. The owner should make sure that it is done.

A weight and balance calculation is necessary in determining how much fuel or baggage can be boarded so as to keep within allowable limits. Check calculations prior to adding fuel to insure against improper loading.

The following pages are forms used in weighing an airplane in production and in computing empty weight, C.G. position, and useful load. Note that the useful load includes fuel, oil, baggage, cargo and passengers. Following this is the method for computing takeoff weight and C.G.

THIS PAGE INTENTIONALLY LEFT BLANK

---

## WEIGHT AND BALANCE DATA

### WEIGHING PROCEDURE

At the time of licensing, Piper Aircraft Corporation provides each airplane with the licensed empty weight and center of gravity location. This data is on Page 5-7.

The removal or addition of an excessive amount of equipment or excessive airplane modifications can affect the licensed empty weight and empty weight center of gravity. The following is a weighing procedure to determine this licensed empty weight and center of gravity location:

#### 1. PREPARATION

- a. Be certain that all items checked in the airplane equipment list are installed in the proper location in the airplane.
- b. Remove excessive dirt, grease, moisture, foreign items such as rags and tools from the airplane before weighing.
- c. Defuel airplane. Then open all fuel drains until all remaining fuel is drained. Operate engine on each tank until all undrainable fuel is used and engine stops.

#### CAUTION

Whenever the fuel system is completely drained and fuel is replenished it will be necessary to run the engine for a minimum of 3 minutes at 1000 RPM on each tank to insure no air exists in the fuel supply lines.

- d. Drain all oil from the engine, by means of the oil drain, with the airplane in ground attitude. This will leave the undrainable oil still in the system. Engine oil temperature should be in the normal operating range before draining.
- e. Place pilot and copilot seats in fourth (4th) notch, aft of forward position. Put flaps in the fully retracted position and all control surfaces in the neutral position. Tow bar should be in the proper location and all entrance and baggage doors closed.
- f. Weigh the airplane inside a closed building to prevent errors in scale readings due to wind.

#### 2. LEVELING

- a. With airplane on scales, block main gear oleo pistons in the fully extended position.

**ARROW**

- b. Level airplane (see diagram) deflating nose wheel tire, to center bubble on level.

**3. WEIGHING - AIRPLANE EMPTY WEIGHT**

- a. With the airplane level and brakes released, record the weight shown on each scale. Deduct the tare, if any, from each reading.

Scale Position and Symbol	Scale Reading	Tare	Weight
Nose Wheel (N)			
Right Main Wheel (R)			
Left Main Wheel (L)			
Airplane Empty Weight, as Weighed (T)			

**4. EMPTY WEIGHT CENTER OF GRAVITY**

- a. The following geometry applies to the PA-28R-200 airplane when airplane is level (See Item 2).

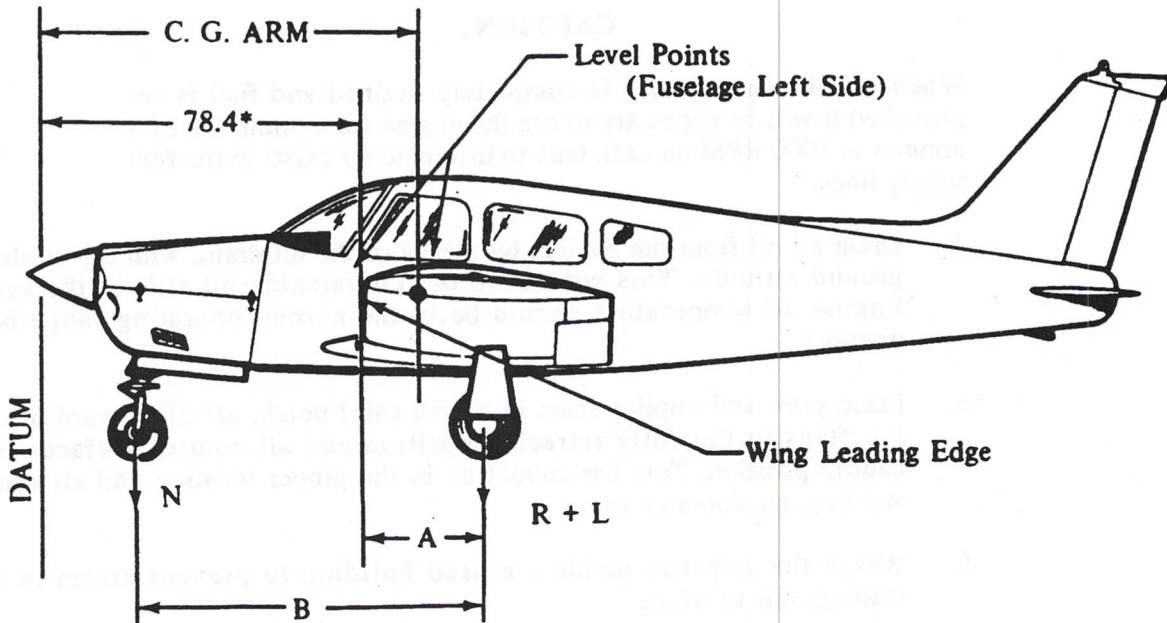

A =

B =

\* The datum is 78.4 inches ahead of the wing leading edge at the intersection of the straight and tapered section.

- b. Obtain measurement "A" by measuring from a plumb bob dropped from the wing leading edge, at the intersection of the straight and tapered section, horizontally and parallel to the airplane centerline, to the main wheel centerline.
- c. Obtain measurement "B" by measuring the distance from the main wheel centerline, horizontally and parallel to the airplane centerline, to each side of the nose wheel axle. Then average the measurements.
- d. The empty weight center of gravity (as weighed including optional equipment and undrainable oil) can be determined by the following formula:

$$\text{C.G. Arm} = 78.4 + A - \frac{B(N)}{T}$$

$$\text{C. G. Arm} = 78.4 + ( \quad ) - \frac{( \quad )( \quad )}{( \quad )} = \quad \text{inches}$$

5. LICENSED EMPTY WEIGHT AND EMPTY WEIGHT CENTER OF GRAVITY

	Weight	Arm	Moment
Empty Weight (as weighed)			
Unusable Fuel (13 1/3 Pints)	+10.0	103.0	+1030
Licensed Empty Weight			



**WEIGHT AND BALANCE DATA**  
**MODEL PA-28R-200 CHEROKEE**

Airplane Serial Number \_\_\_\_\_

Registration Number \_\_\_\_\_

Date \_\_\_\_\_

**AIRPLANE EMPTY WEIGHT**

Item	Weight (Lbs)	C. G. Arm (Inches Aft of Datum)	Moment (In-Lbs)
*Empty Weight	Actual Computed		
Unusable Fuel (13-1/3 pints)	10.0	103.0	1030
Standard Empty Weight			
Optional Equipment			
Licensed Empty Weight			

\*Empty weight is defined as dry empty weight (including paint and hydraulic fluid) plus 1.8 lbs undrainable engine oil.

**AIRPLANE USEFUL LOAD - NORMAL CATEGORY OPERATION**

(Gross Weight) - (Licensed Empty Weight) = Useful Load

(2650 lbs) - (        lbs) =        lbs

THIS LICENSED EMPTY WEIGHT, C.G. AND USEFUL LOAD ARE FOR THE AIRPLANE AS LICENSED AT THE FACTORY. REFER TO APPROPRIATE AIRCRAFT RECORD WHEN ALTERATIONS HAVE BEEN MADE.

ISSUED: MAY 14, 1973  
 REVISED: FEBRUARY 29, 1984

REPORT: VB-549 PAGE 5-7  
 MODEL: PA-28R-200

**C. G. RANGE AND WEIGHT INSTRUCTIONS**

1. Add the weight of all items to be loaded to the licensed empty weight.
2. Use the loading graph to determine the moment of all items to be carried in the airplane.
3. Add the moment of all items to be loaded to the licensed empty weight moment.
4. Divide the total moment by the total weight to determine the C.G. location.
5. By using the figures of Item 1 and Item 4, locate a point on the C.G. range and weight graph. If the point falls within the C.G. envelope, the loading meets the weight and balance requirements.

**SAMPLE LOADING PROBLEM (Normal Category)**

	Weight (Lbs)	Arm Aft Datum (Inches)	Moment (In-Lbs)
Licensed Empty Weight			
Oil (8 quarts)	15	24.5	368
Pilot and Front Passenger	340	80.5	27370
Passengers, Aft (Rear Seat)	340	118.1	40154
Fuel (48 Gal. Maximum)		95.0	
*Baggage		142.8	
Moment due to Retracting of Landing Gear			819
Total Loaded Airplane			

The center of gravity (C.G.) of this sample loading problem is at \_\_\_\_\_ inches aft of the datum line. Locate this point ( ) on the C.G. range and weight graph. Since this point falls within the weight-C.G. envelope, this loading meets the weight and balance requirements.

**IT IS THE RESPONSIBILITY OF THE PILOT AND AIRCRAFT OWNER TO INSURE THAT THE AIRPLANE IS LOADED PROPERLY.**

\*Check Aft C.G. between 150 lbs and 200 lbs.

## LOADING GRAPH

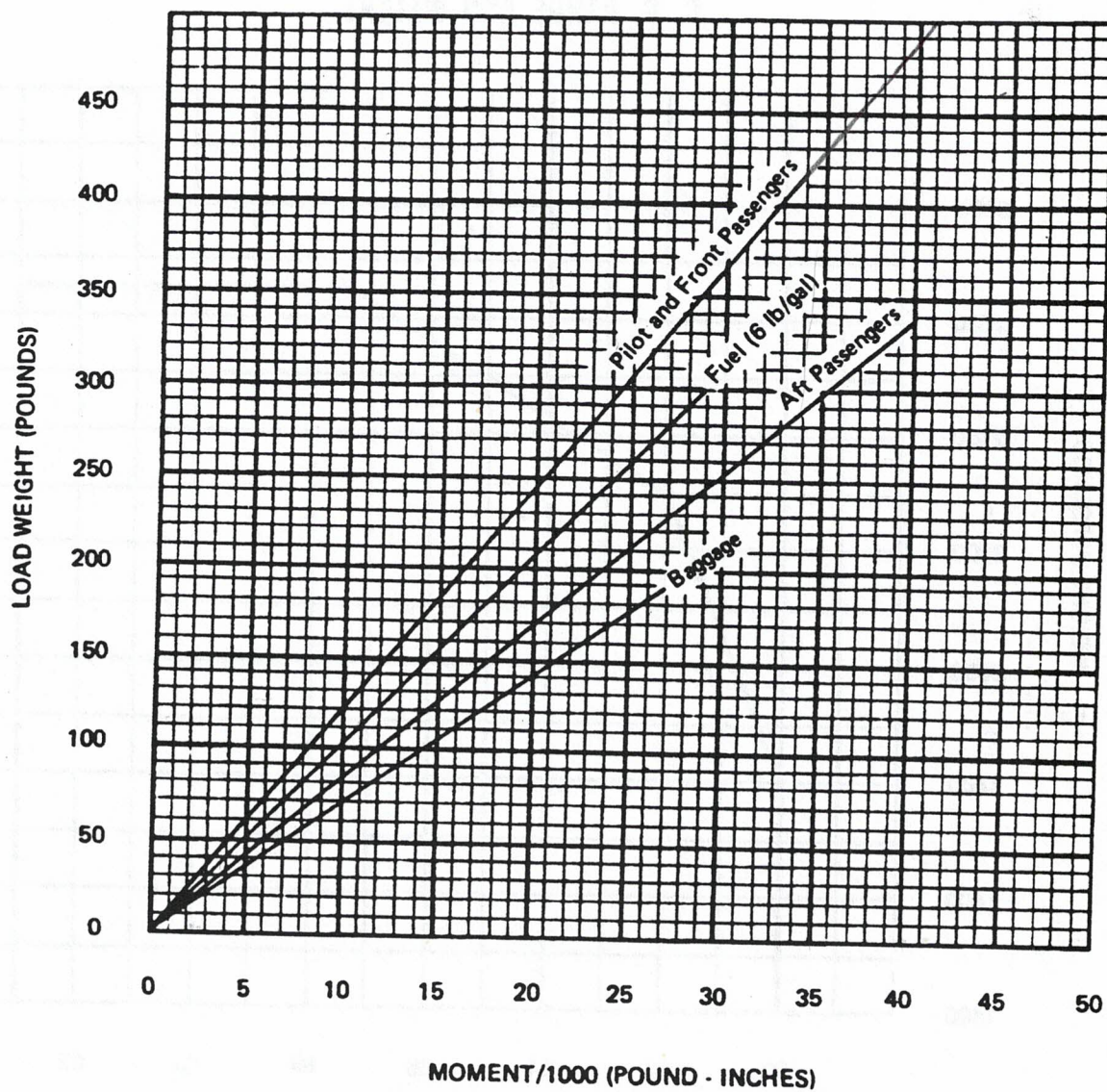

# ARROW

IT IS THE RESPONSIBILITY OF THE OWNER AND PILOT TO ASCERTAIN THAT THE AIRPLANE ALWAYS REMAINS WITHIN THE ALLOWABLE WEIGHT VS. CENTER OF GRAVITY ENVELOPE WHILE IN FLIGHT.

## C. G. RANGE AND WEIGHT

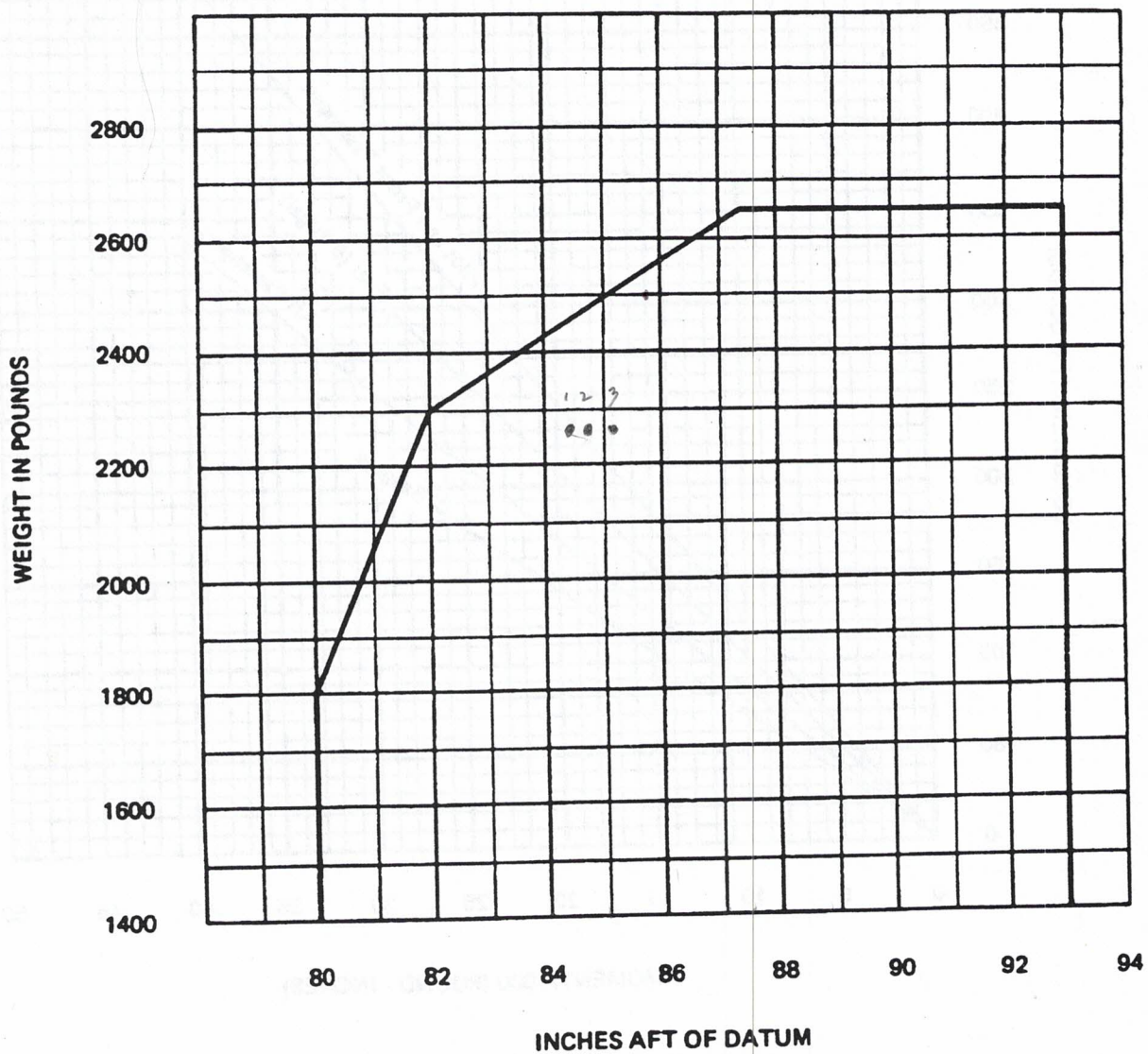

MOMENT DUE TO RETRACTING LANDING GEAR = +819 IN - LBS

## EQUIPMENT LIST

The following is a list of equipment which may be installed in the PA-28R-200. Items marked with an "X" are items installed when the airplane was delivered by the manufacturer.

Item	Item	Weight Lbs.	Arm Aft Datum	Moment	Cert. Basis
A. Propellers and Propeller Accessories					
_____	Propeller - Hartzell Model HC-C2YK-1( )/7666A-2 or HC-C2YK-1( )F/7666A-2*	55.0	-1.9	-105	TC P920
_____	Propeller - McCauley Model B2D34C213/90DHA-16**	49.0	-1.9	-93	TC P7EA
_____	Spinner and Attachment Plate Installation PAC Dwg. 99374*	5.0	-2.2	-11	TC 2A13
_____	Spinner and Attachment Plate Installation PAC Dwg. 35828-2**	4.7	-2.2	-10	TC 2A13
_____	Hydraulic Governor Hartzell Model F-2-7 ( )	5.5	34.1	188	TC P920

\* Serial Nos. 28R-7435001 through 28R-7635516

\*\* Serial Nos. 28R-7635517 and up

ARROW

Item	Item	Weight Lbs.	Arm Aft Datum	Moment	Cert. Basis
B.	Engine and Engine Accessories Fuel and Oil Systems				
_____	Engine - Lycoming Model IO-360-C1C**	326	18.7	6096	TC 1E10
_____	Engine - Lycoming Model IO-360-C1C6***	333	18.7	6227	TC 1E10
_____	Fuel Pump - Electric Auxiliary Weldon #8120-AB	2.8	42.9	120	TC 2A13
_____	Induction Air Filter Fram Model CA-144PL	.5	37.2	19	TC 2A13
_____	Fuel Pump - Engine Driven Lycoming 75247	1.6	32.0	51	TC 1E10
_____	Starter - 12V Prestolite Model MZ-4206 Lycoming 76211	18.0	10.5	189	TC 1E10
_____	Oil Cooler, PAC 67848	2.6	39.7	103	TC 2A13
_____	Oil Filter with Adapter AC 0F5578770 (3.3 lbs. each) (Lycoming #75528)*	3.3	33.1	109	TC 2A13
_____	Oil Filter, Lycoming #LW-13743 (Champion #CH-48110)*	2.8	33.1	93	TC 2A13

\* Serial Nos. 28R-7535001 and up

\*\* Serial Nos. 28R-7435001 through 28R-7635516

\*\*\* Serial Nos. 28R-7635517 and up

---

Item	Item	Weight Lbs.	Arm Aft Datum	Moment	Cert. Basis
	<b>C. Landing Gear and Brakes</b>				
	Two Main Wheel - Brake Assemblies 40-86 Wheel Assembly (Cleveland) 30-55 Brake Assembly (Cleveland) Two Main 4 Ply Rating Tires 6.00-6 with Regular Tubes	34.4	109.8	3777	TC 2A13
	One Nose Wheel Assembly 40-77 Wheel Assembly (Cleveland) (less brake drum) One 4 Ply Rating Tire 5.00-5 Regular Tube	8.1	15.5	126	TC 2A13

**ARROW**

Item	Item	Weight Lbs.	Arm Aft Datum	Moment	Cert. Basis
	D. Electrical Equipment				
_____	One Battery 12V, 25 Amp Hour Rebat S-25	21.9	168.0	3679	TC 2A13
_____	Battery Contactor, Piper 63880-0	1.2	168.0	202	TC 2A13
_____	Stall Warning Detector, Safe Flight Inst. Corp. No. C52207-4	.2	80.2	16	TC 2A13
_____	Switch - Landing Gear Selector Cutler Hammer 8906-K 1736	.2	62.8	13	TC 2A13
_____	Voltage Regulator Wico Electric No. X-16300B	.9	59.4	53	TC 2A13
_____	Overvoltage Relay Wico Electric No. X-16799B	.5	55.4	28	TC 2A13
_____	Starter Relay Piper Dwg. 99130-2	1.0	47.0	47	TC 2A13
_____	Landing Gear Motor Contactor Cole-Hersee #24059 (2) .8 lbs. each	1.6	162.0	259	TC 2A13
_____	Annunciator Lights *	.9	55.5	50	TC 2A13

\*Serial nos. 7535001 and up

Item	Item	Weight Lbs.	Arm Aft Datum	Moment	Cert. Basis
	E. Instruments				
_____	Compass - Piper 67462	.9	59.9	54	TSO C7c
_____	Airspeed Indicator - Piper 67434-2 or -3	.6	61.8	37	TSO C2b
_____	Tachometer - Piper 62177-6*	.7	61.2	43	TC 2A13
_____	Tachometer - Piper 62177-3**	0.7	61.2	43	TC 2A13
_____	Engine Cluster - Piper 95241-2	.8	62.4	50	TC 2A13
_____	Engine Cluster - Piper 95241-3	.8	62.4	50	TC 2A13
_____	Altimeter - Piper PS50008-2, -3, -4 or -5	1.0	60.9	61	TSO C10b
_____	Manifold Pressure and Fuel Flow - Piper PS50031-6	1.7	60.8	103	TSO C45
_____	Airspeed Indicator - Piper PS 50049-5	.6	61.8	37	TSO C2b

\* Serial Nos. 28R-7435001 through 28R-7635516

\*\* Serial Nos. 28R-7635517 and up

ISSUED: MAY 14, 1973  
REVISED: FEBRUARY 28, 1977

REPORT: VB-549 PAGE 5-15  
MODEL: PA-28R-200

**ARROW**

---

THIS PAGE INTENTIONALLY LEFT BLANK

---

Item	Item	Weight Lbs.	Arm Aft Datum	Moment	Cert. Basis
F.	Hydraulic Equipment				
_____	Cylinder Hydraulic Nose Gear Piper 67504	.9	45.0	41	TC 2A13
_____	Cylinder Hydraulic (2) Main Gear Piper 67505 (0.9 lbs. each)	1.8	108.4	195	TC 2A13
_____	Pump Assembly - Piper 67500-2	9.0	159.0	1431	TC 2A13
_____	Switch, Pressure Consolidated Controls #211C243-3	.2	116.7	23	TC 2A13
_____	Valve - Free Fall Piper 67522-2	.3	114.0	34	TC 2A13

**ARROW**

Item	Item	Weight Lbs.	Arm Aft Datum	Moment	Cert. Basis
<b>G. Miscellaneous</b>					
_____	Forward Seat Belts (2) PS50039-4-2 (.75 lbs. each)	1.5	81.9	123	TSO C22
_____	Rear Seat Belts (2) PS50039-4-3 (.70 lbs. each)	1.4	123.0	172	TSO C22
_____	Inertia Safety Belts, Front Seats (2) PS50039-4-17 (0.75 lbs. each)	1.5	119.6	179	TC 2A13
_____	Toe Brakes (Dual) Piper Dwg. 67018-3	11.0	49.6	546	TC 2A13
_____	Front Seat (Right) Piper Dwg. 76171-1	13.7	88.0	1206	TC 2A13
_____	(Right) Piper Dwg. 79337-3	13.9	87.6	1218	TC 2A13
_____	Individual Rear Seats(2) Piper Dwg. 99730-0 and -1 (13.5 lbs. each)	27.0	124.1	3351	TC 2A13
_____	Flight Manual and Logs	2.6	95.1	247	TC 2A13
_____	Tow Bar, Piper Dwg. 67336-0	2.3	155.2	357	TC 2A13

THIS PAGE INTENTIONALLY LEFT BLANK

ARROW

Item	Item	Weight Lbs.	Arm Aft Datum	Moment	Cert. Basis
H.	Engine and Engine Accessories - Fuel and Oil System (Optional Equipment)				
_____	Vacuum Pump Airborne Manufacturing Co. Model 200 CC	5.0	29.6	148	TC 2A13
_____	Oil Filter with Adapter AC 0F5578770 (3.3 lbs. each) (Lycoming #75528) **	3.3	33.1	109	TC 2A13
_____	Oil Filter, Lycoming # LW-13743 (Champion # CH-48110)**	2.8	33.1	93	TC 2A13
_____	Vacuum Pump, Airborne Mfg. Co., Model 211cc PAC 79399-0	3.2	29.6	94	TC 2A13
_____	Low Vacuum Annunciator Light *	Neglect			TC 2A13
_____	Vacuum Regulator, Airborne ** Mfg. Co., #133A4	.6	52.0	31	TC 2A13
_____	Vacuum Regulator, Airborne * Mfg. Co., #2H3-19	.5	52.0	26	TC 2A13

\* Serial nos. 7535001 and up

\*\* Serial nos. 7435001 through 7435331

Item	Item	Weight Lbs.	Arm Aft Datum	Moment	Cert. Basis
I. Electrical Equipment (Optional Equipment)					
_____	Landing Light G.E. Model 4509	.5	13.1	7	TC 2A13
_____	Navigation Light (Rear) Grimes A2064	.2	281.0	56	TSO C30b
_____	Navigation Light (Wing) (2) Grimes A1285-G-12 A1285-R-12 (0.2 lbs. each)	.4	106.6	43	TSO C30b
_____	Auxiliary Power Receptacle Piper 65647	2.7	178.5	482	TC 2A13
_____	External Power Cable Piper 62355-2	4.6	142.8	657	TC 2A13
_____	Cabin Speaker Quincy Spkr. Co. 8B-15052 or Oaktron Ind. GEV 1937	.8	99.0	79	TC 2A13
_____	Cabin Light	.3	99.0	30	TC 2A13
_____	Rotating Beacon	1.5	263.4	395	TC 2A13
_____	Battery 12V, 35 A.H. Reading R-35 (Weight 27.2 lbs.)	* 5.3	168.0	890	TC 2A13

\*Weight and moment difference between standard and optional equipment.

**ARROW**

Item	Item	Weight Lbs.	Arm Aft Datum	Moment	Cert. Basis
I.	Electrical Equipment (Optional Equipment) (cont)				
_____	Heated Pitot Head - Piper 67477-0	.4	100.0	40	TC 2A13
	Anti-Collision Lights Whelen Engineering Co. Piper Dwg. 99030-2 or -5				
_____	Power Supply, Model HS, No. A412A-14 (with fin light only)	2.3	198.0	455	TC 2A13
_____	Power Supply, Model HD, T3 No. A413 (with fin and wing lights)	3.0	198.0	594	TC 2A13
_____	Light, Fin Tip, A408	.4	263.4	105	TC 2A13
_____	Cable, Fin Light, A417-1/300	.4	230.7	92	TC 2A13
_____	Lights, Wing Tip (2) (0.15 lbs. each) No. A429	.3	106.6	32	TC 2A13
_____	Cable, Wing Lights A417-1/298 & A417-1/252	2.0	115.6	231	TC 2A13
_____	Piper Pitch Trim Piper Dwg 67496-2	4.3	155.3	668	TC 2A13
_____	Piper Pitch Trim* Piper Dwg. 67496-3	4.3	155.3	668	TC 2A13

\*Serial nos. 28-7535077 and up.

Item	Item	Weight Lbs.	Arm Aft Datum	Moment	Cert. Basis
J. Autopilots (Optional Equipment)					
	AutoControl III *				
_____	Roll Servo #1C363-1-183R	2.5	122.2	306	STC SA1406SW
_____	Console #1C338 (thru S/N 9999)	1.2	60.1	72	STC SA1406SW
_____	Cables	.7	95.5	67	STC SA1406SW
_____	Attitude Gyro #52D66	2.3	59.4	137	STC SA1406SW
_____	Directional Gyro #52D54	3.2	59.0	189	STC SA1406SW
_____	Omni Coupler #1C388	.9	59.3	53	STC SA1406SW
	AutoFlite II				
_____	Roll Servo #1C363-1-183R	2.5	122.2	306	STC SA1157SW
_____	Cable	.7	93.4	65	STC SA1157SW
_____	Panel Unit #52D75-3 or -4	2.4	59.4	143	STC SA1157SW
	AutoControl III B **				
_____	Roll Servo #1C363-1-183R	2.5	122.2	306	STC SA1406SW
_____	Console, #1C338 (S/N 10000 & up)	1.0	60.1	60	STC SA1406SW
_____	Cables	.5	95.5	48	STC SA1406SW
_____	Attitude Gyro, #52D66	2.7	59.4	160	STC SA1406SW
_____	Directional Gyro, #52D54	2.9	59.0	171	STC SA1406SW
_____	Omni Coupler, #1C388	1.0	59.3	59	STC SA1406SW

\* Serial nos. 7435001 through 7435331

\*\* Serial nos. 7535001 and up

ISSUED: MAY 14, 1973  
REVISED: JUNE 18, 1974

REPORT: VB-549 PAGE 5-23  
MODEL: PA-28R-200

ARROW

THIS PAGE INTENTIONALLY LEFT BLANK

Item	Item	Weight Lbs.	Arm Aft Datum	Moment	Cert. Basis
K. Radio Equipment (Optional Equipment)					
_____	Narco Mark 16 Transceiver, Single *	7.5	56.9	427	TC 2A13
_____	Narco Mark 16 Transceiver, Dual *	15.0	56.9	854	TC 2A13
_____	Narco VOA-50M Omni Converter *	2.1	59.9	126	TC 2A13
_____	Narco VOA-40M Omni Converter *	1.9	59.9	114	TC 2A13
_____	Narco VOA-40 Omni Converter *	1.9	59.9	114	TC 2A13
_____	Nav. Receiving Antenna	.5	265.0	133	TC 2A13
_____	Cable, Nav. Antenna	.9	157.0	141	TC 2A13
_____	#1 VHF Comm. Antenna	.3	157.8	47	TC 2A13
_____	Cable, #1 VHF Comm. Antenna	.4	103.4	41	TC 2A13
_____	#2 VHF Comm. Antenna	.3	192.8	58	TC 2A13
_____	Cable, #2 VHF Comm. Antenna	.5	147.5	60	TC 2A13
Anti Static Kit					
_____	#1 VHF Comm. Antenna	1.0	160.8	161	TC 2A13
_____	Cable, #1 VHF Comm. Antenna	.4	103.4	41	TC 2A13
_____	#2 VHF Comm. Antenna	1.0	195.8	196	TC 2A13
_____	Cable, #2 VHF Comm. Antenna	.5	120.9	60	TC 2A13
_____	Low Frequency Antenna	.5	147.5	74	TC 2A13
_____	Static Wicks	—	—	—	TC 2A13

\*Serial nos. 7435001 through 7435331

**ARROW**

Item	Item	Weight Lbs.	Arm Aft Datum	Moment	Cert. Basis
<b>K. Radio Equipment (Optional Equipment) (cont)</b>					
_____	Bendix ADF-T-12C or D * Receiver Model 201F	3.9	59.4	232	TC 2A13
_____	Receiver Model 201 C or D	3.5	59.4	208	TC 2A13
_____	Audio Amplifier 102A	.8	52.4	42	TC 2A13
_____	Servo Indicator 551A	1.7	60.9	104	TC 2A13
_____	Loop Antenna 2321E	1.3	160.8	209	TC 2A13
_____	Cable, Interconnecting	2.3	108.0	248	TC 2A13
_____	Sense Antenna and Cable	.4	150.0	60	TC 2A13
_____	Narco Comm 10 ( )	3.9	57.4	224	TC 2A13
_____	Narco Comm 11 ( )	3.6	57.4	207	TC 2A13
_____	Dual Comm 11 ( )	7.1	57.4	408	TC 2A13
_____	Narco Nav 10	1.9	58.6	111	TC 2A13
_____	Narco Nav 11	2.8	58.6	164	TC 2A13
_____	Narco Nav 12	3.4	58.6	199	TC 2A13
_____	Dual Nav 11	5.6	58.6	328	TC 2A13
_____	King KX-170 ( ) or KX-175 ( )	7.5	56.6	425	TC 2A13
_____	Dual KX-170 ( ) or KX-175 ( )	15.0	56.6	849	TC 2A13
_____	King KI-201 ( )	2.5	59.9	150	TC 2A13
_____	King KI-211 ( )	3.3	59.9	198	TC 2A13
_____	Dual KI-201 ( )	5.0	59.9	300	TC 2A13
_____	Dual KNI-520	5.6	59.9	335	TC 2A13
_____	Narco ADF-31 *				
_____	Panel Unit	5.0	58.5	293	TC 2A13
_____	Sensor Unit	2.5	162.7	407	TC 2A13
_____	Sensor Cable	2.3	105.6	243	TC 2A13
_____	Sensor Antenna and Cable	.4	150.0	60	TC 2A13

\*Serial nos. 7435001 through 7435331

Item	Item	Weight Lbs.	Arm Aft Datum	Moment	Cert. Basis
K. Radio Equipment (Optional Equipment) (cont)					
	King KR-85				
_____	Receiver	4.3	59.4	255	TC 2A13
_____	Servo Indicator	1.2	61.3	74	TC 2A13
_____	Loop Antenna	1.3	161.5	210	TC 2A13
_____	Loop Cable	1.8	105.5	190	TC 2A13
_____	Audio Amplifier	.8	51.0	41	TC 2A13
_____	Sense Antenna and Cable	.4	147.5	59	TC 2A13
_____	Narco CP-25B/125 Selector *				
_____	Panel	1.2	55.0	66	TC 2A13
_____	Narco MBT-12-R Marker Beacon	3.1	69.1	214	TC 2A13
_____	Narco Comm 110 *	3.0	57.4	172	TC 2A13
_____	Narco Comm 111	3.0	57.4	172	TC 2A13
_____	Narco Nav 110 *	1.7	58.6	100	TC 2A13
_____	Narco Nav 111	2.5	58.6	147	TC 2A13
_____	Narco Nav 112	3.3	58.6	193	TC 2A13
	PM-1 Marker Beacon *				
_____	Receiver	1.1	121.3	133	TC 2A13
_____	Remote Unit	.3	128.4	39	TC 2A13
_____	Cable	.3	85.0	26	TC 2A13
	UGR-2A Glide Slope				
_____	Receiver	2.4	173.8	417	TC 2A13
_____	Cable	1.8	128.0	230	TC 2A13
_____	Antenna	.4	92.4	37	TC 2A13
_____	Cable, Antenna	.5	145.0	73	TC 2A13
	King KN60C DME				
_____	Receiver	6.8	56.7	386	TC 2A13
_____	Antenna	.2	112.1	22	TC 2A13
_____	Cable, Antenna	.3	83.1	25	TC 2A13
_____	King KN61 DME	12.5	179.0	2237	TC 2A13
_____	King KN65A DME	13.0	174.9	2274	TSO C66a

\*Serial nos. 7435001 through 7435331

ISSUED: MAY 14, 1973  
REVISED: DECEMBER 8, 1975

REPORT: VB-549 PAGE 5-27  
MODEL: PA-28R-200

**ARROW**

Item	Item	Weight Lbs.	Arm Aft Datum	Moment	Cert. Basis
<b>K. Radio Equipment (Optional Equipment) (cont)</b>					
<b>IFD Starlight Transponder *</b>					
_____	Panel Unit	2.3	59.4	137	TC 2A13
_____	Antenna	.1	47.2	5	TC 2A13
_____	Cable	.3	46.5	14	TC 2A13
<b>IFD Skyline 300 Transponder *</b>					
_____	Panel Unit	1.7	60.4	103	TC 2A13
_____	Remote Unit	1.8	53.1	96	TC 2A13
_____	Antenna	.1	47.5	5	TC 2A13
_____	Cable	.1	52.1	5	TC 2A13
<b>Piper Automatic Locator</b>					
_____	Transmitter, Piper Dwg. 79265-0	1.7	236.2	402	TC 2A13
_____	Transmitter, Piper Dwg. 79265-6	1.3	236.2	307	TC 2A13
_____	Transmitter, Piper Dwg. 79761-4	1.7	236.2	402	TC 2A13
_____	Antenna & Coax	.2	224.4	45	TC 2A13
_____	Shelf & Access Hole	.33	235.4	78	TC 2A13
<b>King KT76/78 Transponder</b>					
_____	Panel Unit	3.1	58.1	180	TC 2A13
_____	Antenna & Cable	—	—	—	TC 2A13
_____	Narco AT-50A Transponder (Includes Antenna & Cable)	3.0	57.3	172	TC 2A13
_____	King KMA-20 ( ) Audio Panel	2.8	60.2	169	TC 2A13
_____	Antenna	.5	116.3	58	TC 2A13
_____	Cable	.4	87.5	35	TC 2A13
_____	Audio Selector Panel - Piper * 99395-0, -2, or -3	.7	61.3	43	TC 2A13
_____	Microphone (Carbon) Piper Dwg. 68856-10	.3	64.9	19	TC 2A13
_____	Microphone (Dynamic) Piper Dwg. 68856-12	.3	64.9	19	TC 2A13
_____	Headset	.5	60.0	30	TC 2A13

\*Serial nos. 7435001 through 7435331

Item	Item	Weight Lbs.	Arm Aft Datum	Moment	Cert. Basis
<b>K. Radio Equipment (Optional Equipment) (cont)</b>					
_____	King KI-213 VOR/LOC/GS Indicator *	2.5	60.4	151	TC 2A13
King KR-86 ADF *					
_____	Receiver	3.9	59.4	232	TC 2A13
_____	Loop Antenna	1.5	161.5	242	TC 2A13
_____	Loop Cable	1.3	105.5	137	TC 2A13
_____	Audio Amplifier	0.8	51.0	41	TC 2A13
_____	Sense Antenna & Cable	0.4	147.5	59	TC 2A13
King KR-86 ADF (2nd) *					
_____	Receiver	3.9	59.4	232	TC 2A13
_____	Loop Antenna	1.5	150.7	226	TC 2A13
_____	Loop Cable	1.3	105.0	137	TC 2A13
_____	Sense Antenna & Cable	3.0	147.5	443	TC 2A13
_____	King KN-73 Glide Slope Receiver *	3.2	184.3	590	TC 2A13
_____	King KN-77 VOR/LOC Converter *	3.6	183.6	661	TC 2A13
_____	King Dual KN-77 VOR/LOC Converter *	7.8	183.6	1432	TC 2A13
King KN-65 DME *					
_____	Receiver	7.6	201.6	1532	TC 2A13
_____	Antenna	0.2	112.1	22	TC 2A13
_____	Cable, Antenna	0.3	157.1	47	TC 2A13
_____	Indicator	1.0	60.0	60	TC 2A13
King KN-74 R-Nav *					
_____	Computer	3.7	57.6	213	TC 2A13
_____	Cable Assy.	1.0	53.0	53	TC 2A13
_____	King KI-214 VOR/LOC Indicator *	3.3	59.9	198	TC 2A13

\*Serial nos. 7535001 and up

ARROW

Item	Item	Weight Lbs.	Arm Aft Datum	Moment	Cert. Basis
K.	Radio Equipment (Optional Equipment) (cont)				
_____	Narco Comm 11B VHF Transceiver	3.9	57.4	224	TC 2A13
_____	Narco Dual Comm 11B VHF Transceiver *	7.8	57.4	448	TC 2A13
_____	Narco Dual Comm 111 VHF Transceiver *	6.0	57.4	344	TC 2A13
_____	Narco Comm 111B VHF Transceiver	3.9	57.4	224	TC 2A13
_____	Narco Dual Comm 111B VHF Transceiver *	7.8	57.4	448	TC 2A13
_____	Narco Nav 14 VHF Receiver *	2.5	57.4	144	TC 2A13
_____	Narco Nav 114 VHF Receiver *	2.5	57.4	144	TC 2A13
_____	Narco UGR-3 Glide Slope *				
_____	Receiver	2.4	173.8	417	TC 2A13
_____	Cable	1.8	128.0	230	TC 2A13
_____	Antenna	0.4	92.4	37	TC 2A13
_____	Cable, Antenna	0.5	145.0	73	TC 2A13
_____	Narco CP-125 Audio Selector Panel *	2.2	55.0	121	TC 2A13
_____	Narco ADF-140 *				
_____	Receiver	2.5	58.3	146	TC 2A13
_____	Servo Indicator	1.3	61.0	79	TC 2A13
_____	Loop Antenna	1.6	162.0	259	TC 2A13
_____	Cable, Loop	0.6	105.5	63	TC 2A13
_____	Sense Antenna and Cable	0.4	147.5	59	TC 2A13

\*Serial nos. 7535001 and up

Item	Item	Weight Lbs.	Arm Aft Datum	Moment	Cert. Basis
K. Radio Equipment (Optional Equipment) (cont)					
	Narco Dual ADF-140 *				
_____	Receivers	5.0	58.3	292	TC 2A13
_____	Dual Needle Indicator	3.5	61.0	214	TC 2A13
_____	Loop Antenna # 1	1.6	162.0	259	TC 2A13
_____	Cable, Loop # 1	0.6	105.5	63	TC 2A13
_____	Sense Antenna and Cable # 1	0.4	143.8	58	TC 2A13
_____	Loop Antenna # 2	1.6	150.0	240	TC 2A13
_____	Cable, Loop # 2	0.6	93.5	56	TC 2A13
_____	Sense Antenna and Cable # 2	3.0	143.8	431	TC 2A13
_____	Remote for Dual Ind.	2.0	185.5	371	TC 2A13
	Narco DME-190 *				
_____	Receiver	5.2	61.8	321	TC 2A13
_____	Antenna	0.3	113.9	34	TC 2A13
_____	Cable, Antenna	0.4	85.6	34	TC 2A13
	Microphone (Dynamic) *				
_____	Piper Dwg. 68856-11	0.6	69.9	42	TC 2A13

\*Serial nos. 7535001 and up



Item	Item	Weight Lbs.	Arm Aft Datum	Moment	Cert. Basis
L. Instruments (Optional Equipment)					
_____	Suction Gauge - Piper 99480-0 or -2	.5	62.2	31	TC 2A13
_____	Vacuum Filter, Piper 66673	.3	52.0	16	TC 2A13
_____	Indicator - Rate of Climb - Piper 99010-2, -4, or -5	1.0	60.9	61	TSO C8b
_____	Indicator - Rate of Climb - Piper 99010-3	.5	62.2	31	TSO C8b
_____	Attitude Gyro - Piper 99002-2, -3, -4, or -8	2.2	59.4	131	TSO C4c
_____	Directional Gyro - Piper 99003-2, -3, -4, or -7	2.6	59.7	155	TSO C5c
_____	Air Temperature Gauge Piper Dwg. 79316	.2	72.6	15	TC 2A13
_____	Clock	.4	62.4	25	TC 2A13
_____	Turn and Slip Indicator - Piper PS50030-2 or -3	2.6	59.7	155	TSO C3B Type II
_____	Exhaust Gas Temperature Gauge Piper 99026	.7	55.4	39	TC 2A13
_____	Tru-Speed Indicator Piper 67433-2 or -3 or PS50049-4	(same as Standard Equipment)			
_____	Encoding Altimeter PS50008 -6 or -7	* .9	60.3	54	TSO C10b, C88

\* Weight and Moment difference between standard and optional equipment.

**ARROW**

Item	Item	Weight Lbs.	Arm Aft Datum	Moment	Cert. Basis
	L. Instruments (Optional Equipment) (cont)				
_____	Engine Hour Meter* Piper Dwg. 79548-0	.3	61.2	18	TC 2A13
_____	MK10 Radar Altimeter* Piper Dwg. 37693-2	5.4	156.3	844	TC 2A13
_____	NSD-360 Gyro*	4.1	59.0	241	TSO C52a TSO C5c
_____	Narco OC-110* Converter and Mount	2.1	185.5	390	TSO C36c C40a

\*Serial nos. 28R-7635001 and up.

Item	Item	Weight Lbs.	Arm Aft Datum	Moment	Cert. Basis
M. Miscellaneous (Optional Equipment)					
_____	Assist Step Piper 65384-0	1.8	156.0	281	TC 2A13
_____	Assist Strap and Coat Hook Piper 62353-5	.2	109.5	22	TC 2A13
_____	Assist Strap Piper Dwg. 79455	.2	109.5	22	TC 2A13
_____	Inertia Safety Belts, Rear Seats (2) PS50039-4-14	1.6	140.3	224	TC 2A13
_____	Lighter 200462 (12V Universal)	.2	62.9	13	TC 2A13
_____	Fire Extinguisher, Scott Aviation 42211-00 Piper Dwg. 76167-2	4.6	71.0	327	TC 2A13
_____	Headrests, (2) (1.0 lbs each) (Front) Piper Dwg. 99255-3	2.0	94.5	189	TC 2A13
_____	(Front) Piper Dwg. 79337-18	2.0	94.5	189	TC 2A13
_____	Headrests, (2) (1.0 lbs each) (Rear) Piper Dwg. 99255-3	2.0	132.1	264	TC 2A13
_____	(Rear) Piper Dwg. 79337-18	2.0	132.1	264	TC 2A13
_____	Alternate Static Source	.4	61.0	24	TC 2A13
Calibrated Alternate Static Source					
Placard Required: Yes _____ No _____					
_____	Zinc Chromate Finish	5.0	158.0	790	TC 2A13
_____	Air Conditioner Instl.	68.9	105.0	7235	TC 2A13
_____	Vert. Adj. Front Seat				
_____	(Left) Piper Dwg. 76340-0	* 6.6	80.7	533	TC 2A13
_____	(Left) Piper Dwg. 79591-0	* 6.6	80.3	530	TC 2A13

\* Weight and Moment difference between standard and optional equipment.

**ARROW**

Item	Item	Weight Lbs.	Arm Aft Datum	Moment	Cert. Basis
<b>M. Miscellaneous (Optional Equipment) (cont)</b>					
_____	Vert. Adj. Front Seat (Right) Piper Dwg. 76340-1	* 6.8	80.0	544	TC 2A13
_____	(Right) Piper Dwg. 79591-1	* 6.6	79.6	525	TC 2A13
_____	Super Cabin Sound Proofing Piper Dwg. 79030-4	18.1	86.8	1571	TC 2A13
_____	Cabin Overhead Vent System Piper Dwg. 76304-3	5.9	157.9	932	TC 2A13
_____	Cabin Overhead Vent System With Ground Ventilating Blower Piper Dwg. 76304-4	13.5	170.4	2300	TC 2A13
_____	Cabin Overhead Vent System Piper Dwg. 76304-11	6.4	159.6	1022	TC 2A13
_____	Cabin Overhead Vent System With Ground Ventilating Blower Piper Dwg. 76304-12	14.0	170.7	2390	TC 2A13
_____	Corrosive Resistant Kit	3.0	106.0	318	TC 2A13
_____	Stainless Steel Control Cables	—	—	—	TC 2A13

**TOTAL OPTIONAL EQUIPMENT** \_\_\_\_\_

**EXTERIOR FINISH**

Base Color \_\_\_\_\_

Registration No. Color \_\_\_\_\_

Trim Color \_\_\_\_\_

Type Finish \_\_\_\_\_

Accent Color \_\_\_\_\_

\*Weight and Moment difference between standard and optional equipment.

**LOADING INSTRUCTIONS**

**THIS SECTION IS NOT  
APPLICABLE TO THIS AIRPLANE**

BLANK PAGE

LOADING INSTRUCTIONS

THIS SECTION IS NOT  
APPLICABLE TO THIS APPARATUS



# OPERATING INSTRUCTIONS

Preflight .....	7-1
Starting Engine .....	7-2
Starting Engine When Cold .....	7-2
Starting Engine When Hot .....	7-2
Starting Engine When Flooded .....	7-3
Starting Engine With External Power .....	7-3
Warm-Up and Ground Check .....	7-3
Takeoff .....	7-4
Climb .....	7-5
Stalls .....	7-5
Cruising .....	7-6
Approach and Landing .....	7-7
Stopping Engine .....	7-7
Airspeed Data .....	7-8
Moorings .....	7-8
Weight and Balance .....	7-8
Emergency Locator Transmitter .....	7-8
Air Conditioning .....	7-10
Air Conditioner Operational Check Procedure .....	7-10
Air Conditioner Effects on Airplane Performance .....	7-10

BLANK PAGE

---

**OPERATING INSTRUCTIONS****PREFLIGHT**

The airplane should be given a thorough visual inspection prior to each flight. Particular attention should be given to the following items:

1. Master switch and ignition OFF; landing gear switch DOWN; remove seat belt securing control wheel.
2. a. Check for external damage and operational interference of control surfaces or hinges.  
b. Insure that wings and control surfaces are free of snow, ice or frost.
3. a. Visually check fuel supply; secure caps.  
b. Drain all fuel system sumps and lines.  
c. Check that fuel system vents are open.
- d. Check landing gear shock struts for proper inflation (approximately 2 inches showing).
- e. Check hydraulic lines and landing gear cylinders for leaks.

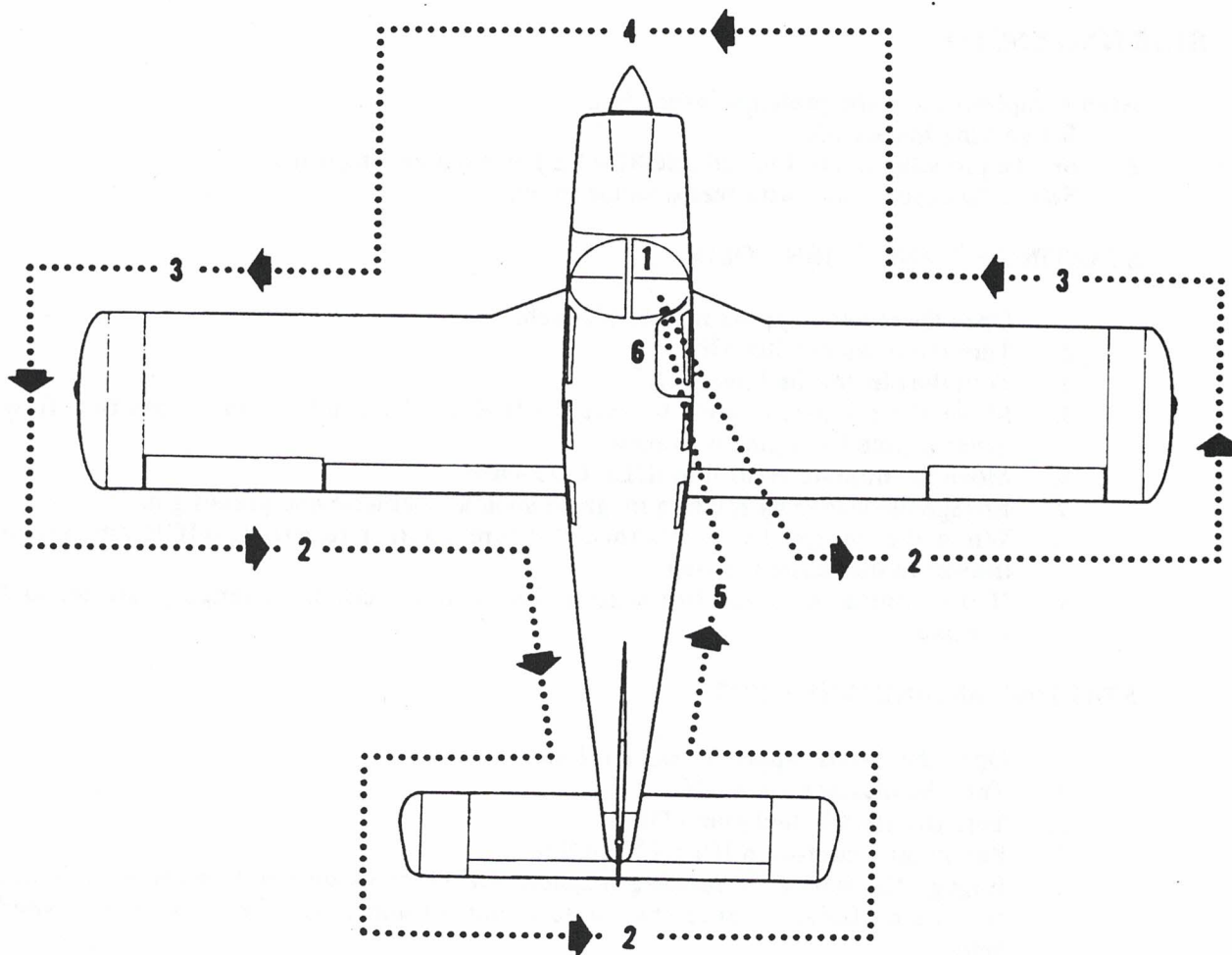

## ARROW II

---

- f. Check tires for cuts, wear and proper inflation.
- g. Check brake blocks and discs for wear and damage.
4.
  - a. Check windshield for cleanliness.
  - b. Check propeller and spinner for defects or nicks.
  - c. Check for obvious fuel or oil leaks.
  - d. Check oil level. (Insure dipstick is properly seated.)
  - e. Check cowling and inspection covers for security.
  - f. Check cowl scoop for obstructions.
  - g. Check nose wheel tire for inflation or wear.
  - h. Check nose gear shock strut for proper inflation (approximately 2-3/4 inches showing).
  - i. Check hydraulic lines and landing gear cylinder for excessive leaks.
  - j. Check for foreign matter in air inlet.
5.
  - a. Stow tow bar and control locks if used.
  - b. Check baggage for proper storage and security.
  - c. Close and secure the baggage compartment door.
6.
  - a. Upon entering airplane check that all primary flight controls operate properly, and that aircraft is properly loaded.
  - b. Close and secure cabin door.
  - c. Check that required papers are in order and in the airplane.

### STARTING ENGINE

After completion of the preflight inspection:

1. Set parking brakes ON.
2. Set the propeller control in full INCREASE RPM (control forward).
3. Select the desired tank with fuel selector valve.

### STARTING ENGINE WHEN COLD

1. Open the throttle approximately 1/2 inch.
2. Turn the master switch ON.
3. Turn the electric fuel pump ON.
4. Move the mixture control to FULL RICH until an indication on the fuel flow meter is noted. (Engine is primed.)
5. Move the mixture control to IDLE CUT-OFF.
6. Engage the starter by rotating magneto switch clockwise and pressing in.
7. When the engine fires, advance mixture control to FULL RICH and move throttle to the desired setting.
8. If the engine does not fire within five to ten seconds, disengage starter and reprime.

### STARTING ENGINE WHEN HOT

1. Open the throttle approximately 1/2 inch.
2. Turn the master switch ON.
3. Turn the electric fuel pump ON.
4. Put mixture control in IDLE CUT-OFF.
5. Engage the starter by rotating magneto switch clockwise and pressing in. When the engine fires, advance the mixture control and move the throttle to desired setting.

---

### STARTING ENGINE WHEN FLOODED

1. Open the throttle full.
2. Turn the master switch ON.
3. Turn the electric fuel pump OFF.
4. Put mixture control in IDLE CUT-OFF.
5. Engage the starter by rotating the magneto switch clockwise and pressing in. When the engine fires, advance the mixture control and retard the throttle.

When the engine is firing evenly, advance the throttle to 800 RPM. If oil pressure is not indicated within 30 seconds, stop the engine and determine the trouble. In cold weather it will take a few seconds longer to get an oil pressure indication. If the engine has failed to start, refer to the "Engine Troubles and Their Remedies" section of the Lycoming Operating Handbook.

Starter manufacturers recommend that cranking periods be limited to 30 seconds with a two minute rest between cranking periods. Longer cranking periods will shorten the life of the starter.

### STARTING WITH EXTERNAL POWER\*

An optional feature known as Piper External Power (PEP) allows the operator to use an external battery to crank the engine without having to gain access to the aircraft battery.

The procedure is as follows:

1. Turn aircraft MASTER SWITCH to OFF.
2. Connect RED lead of PEP kit jumper cable to POSITIVE (+) terminal of external 12 volt battery and BLACK lead to NEGATIVE (-) terminal.
3. Insert plug of jumper cable into socket located on aircraft fuselage.
4. Turn aircraft MASTER SWITCH to ON and proceed with NORMAL engine starting technique.
5. After engine has been started, turn MASTER SWITCH to OFF and remove jumper cable plug from aircraft.
6. Turn aircraft MASTER SWITCH to ON and check alternator ammeter for indication of output. DO NOT ATTEMPT FLIGHT IF THERE IS NO INDICATION OF ALTERNATOR OUTPUT.

### WARM-UP AND GROUND CHECK

Warm-up the engine at 1400 to 1500 RPM for not more than two minutes in warm weather, four minutes in cold weather. Avoid prolonged idling at low RPM as this practice may result in fouled spark plugs. If necessary to hold before take-off, it is recommended that engine be operated at 1400-1500 RPM.

The magnetos should be checked at 2000 RPM with the propeller set at increase RPM. Drop off on either magneto should not exceed 175 RPM and the differential should be not more than 50 RPM. Prolonged operation on one magneto should be avoided.

\*Optional Equipment

## ARROW II

---

Check vacuum gauge. Indicator should read 5" Hg  $\pm$  .1" Hg at 2000 RPM. Check both the oil temperature and pressure. The temperature may be low for some time if the engine is being run for the first time of the day, but as long as the pressure is within limits the engine is ready for takeoff. For air conditioner ground check, refer to page 7-10.

Check the annunciator panel lights with the press-to-test button\*.

The propeller control should be moved through its complete range to check for proper operation and then placed to full increase RPM for take-off. To obtain maximum RPM, push the pedestal-mounted control fully toward the instrument panel. In cold weather the propeller control should be cycled at least three times to ensure that warm engine oil has circulated through the system.

The electric fuel pump should be turned off momentarily during ground check to make sure that the engine driven pump is operating. The electric fuel pump should be on during take-off to prevent loss of power should the engine driven pump fail. The engine is warm enough for take-off when the throttle can be opened without the engine faltering.

### TAKE-OFF

Just before take-off the following items should be checked:

1. Fuel - on proper tank
2. Electric fuel pump - ON
3. Engine gauges - checked
4. Flight instruments - checked and set as required
5. Master Switch - ON
6. Alternate air - closed
7. Prop - set
8. Mixture - set
9. Seat backs - erect
10. Fasten belts/harness
11. Empty seats - seat belts snugly fastened
12. Flaps - exercised and set
13. Trim tab - set
14. Controls - free
15. Door - latched
16. Air condition - OFF

The takeoff technique is conventional for the Cherokee Arrow II. The tab should be set slightly aft of neutral, with the exact setting determined by the loading of the aircraft. Allow the airplane to accelerate to 60 to 70 MPH. Then ease back on the wheel enough to let the airplane fly from the ground.

\*Serial nos. 7535001 and up

**Short Field, Obstacle Clearance:**

Lower flaps to 25° (second notch), accelerate aircraft to 60-65 MPH and ease back on the wheel to rotate. After breaking ground, accelerate to best angle of climb speed, 85 MPH, select gear "up"\* and continue climb while accelerating to best rate of climb speed, 100 MPH, and slowly retract the flaps while climbing out.

**Soft Field, Obstacle Clearance:**

Lower flaps to 25° (second notch), accelerate aircraft, pull nose gear off as soon as possible and lift off at lowest possible airspeed. Accelerate just above the ground to best angle of climb speed, 85 MPH, select gear "up"\* and climb past obstacle clearance height. Continue climb while accelerating to best rate of climb speed, 100 MPH, and slowly retract the flaps.

**Soft Field, No Obstacle:**

Proceed as above after gear retraction, continue climb at best rate of climb speed, 100 MPH, and slow retract the flaps.

\*If desired, on aircraft equipped with backup gear extender, the "Override Engaged" position can be selected and latched before takeoff. The gear will now retract as soon as the gear selector switch is placed in the "up" position. Care should be taken not to retract the gear prematurely, in event aircraft should settle back onto the runway. If the override lock is used for takeoff, disengage as soon as sufficient terrain and obstacle clearance is obtained, to return the gear system to normal operation.

**CLIMB**

The best rate of climb at gross weight will be obtained at 95 MPH with gear down and 100 MPH with gear up. The best angle of climb may be obtained at 85 MPH with gear down and 96 MPH with gear up. For climbing en route a speed of 110 MPH is recommended. This will produce better forward speed and increase visibility over the nose during the climb, with little sacrifice in rate of climb. Air conditioner may be turned on after all obstacles have been cleared.

**STALLS**

Angle of Bank	Flaps 40°	Flaps Retracted
0°	64 MPH	71 MPH
20°	66 MPH	73 MPH
40°	73 MPH	81 MPH
60°	90 MPH	100 MPH

Power Off - Gear Up or Down - Gross Weight 2650 Lbs.

## ARROW II

---

### CRUISING

The cruising speed of the Cherokee Arrow II is determined by many factors, including power setting, altitude, temperature, loading, and equipment installed on the airplane. The normal cruising power is 75% of the rated horsepower of the engine. True airspeeds which may be obtained at various altitudes and power settings can be determined from the charts in "Section XIII" of this manual.

When selecting RPM below 2400, limiting manifold pressure for continuous operation, as specified by the Lycoming Operator's Manual, should be observed.

To INCREASE power, first increase RPM (propeller control); then increase manifold pressure (throttle control).

To DECREASE power, first decrease manifold pressure (throttle); then decrease RPM (propeller control).

Use of the mixture control in cruising flight reduces fuel consumption significantly, especially at higher altitudes. The mixture should be leaned during cruising operation above 5000 feet altitude and at the pilot's discretion at lower altitudes when 75% power or less is being used. If any doubt exists as to the amount of power being used, the mixture should be in the FULL RICH position for all operations under 5000 feet.

To lean the mixture, disengage lock\* and pull the mixture control until the engine becomes rough, indicating that the lean mixture limit has been reached in the leaner cylinders. Then enrich the mixture by pushing the control toward the instrument panel until engine operation becomes smooth. The fuel flow meter will give a close approximation of the fuel being consumed.

If the airplane is equipped with the optional exhaust gas temperature (EGT) gauge, a more accurate means of leaning is available to the pilot. For this procedure, refer to the Avco Lycoming Operator's Manual.

In order to keep the airplane in best lateral trim during cruising flight, the fuel should be used alternately from each tank. It is recommended that one tank be used for one hour after take-off, then the other tank be used for two hours, then return to the first tank for one hour. Each tank will then contain approximately 1/2 hour of fuel if tanks were full (24 gallons usable each tank) at take-off. Do not run tanks completely dry in flight.

#### NOTE

There are no mechanical uplocks in the landing gear system. In the event of a hydraulic system malfunction, the landing gear will free fall to the gear down and locked position. The pilot should be aware that the airplane true airspeed with gear down is approximately 75% of the gear retracted airspeed for any given power setting. Allowances for the reduction in airspeed and range should be made when planning extended flight between remote airfields or flight over water.

\*Serial nos. 7535001 and up

---

## APPROACH AND LANDING

Before landing check list:

1. Seat backs - erect
2. Fasten belts/harness
3. Fuel - on proper tank
4. Fuel pump - ON
5. Mixture - set
6. Propeller - set
7. Gear - DOWN (150 MPH MAX)
8. Flaps - set (125 MPH)
9. Air conditioner - OFF

The airplane should be trimmed to an approach speed of about 90 MPH with the flaps and gear extended. The flaps can be lowered at speeds up to 125 MPH and the gear can be extended at speeds up to 150 MPH if desired. The propeller should be set at approximately 2600 RPM to facilitate ample power for emergency go-around and to prevent over-speeding of the engine if the throttle is advanced sharply. The mixture control should be kept in the full rich position to insure maximum acceleration if it should be necessary to open the throttle again.

The amount of flap used during landings and the speed of the aircraft at contact with the runway should be varied according to the landing surface and conditions of wind and airplane loading. It is generally good practice to contact the ground at the minimum possible safe speed consistent with existing conditions.

Normally, the best technique for short and slow landings is to use full flaps and enough power to maintain the desired approach flight path. The mixture should be full rich, fuel selector on the fullest tank, and the electric fuel pump on. The airspeed should be reduced during flare out and contact with the ground should be made close to stalling speed. After ground contact, the nose wheel should be held off. As the airplane slows down, the nose should be eased down and the brakes applied. There will be less chance of skidding the tires if the flaps are retracted before applying the brakes. Braking is most effective when back pressure is applied to the control wheel, putting most of the airplane weight on the main wheels without lifting the nose wheel. In high wind conditions, although it may be desirable to approach at higher than normal speeds, it is still desirable to make contact with the runway when the airplane is approximately at its minimum speed.

## STOPPING ENGINE

At the pilot's discretion, the flaps should be raised and the electric fuel pump turned off. After parking, the air conditioner and radios should be turned off, the propeller set to increase RPM and the engine then stopped by disengaging mixture control lock\* and pulling the mixture control to idle cut-off. The throttle should be left full aft to avoid engine vibration while stopping. Then the ignition and master switches should be turned off and the parking brake set.

\*Serial nos. 7535001 and up

## ARROW II

---

### AIRSPEED DATA

All airspeeds quoted in this manual are calibrated unless otherwise noted. Calibrated airspeed is indicated airspeed corrected for instrument and position errors. The following table gives the correlation between indicated airspeed and calibrated airspeed if zero instrument error is assumed. This calibration is valid only when flown at maximum gross weight in level flight.

#### AIRSPEED CORRECTION TABLE

Flaps 0°													
IAS - MPH	60	70	80	90	100	110	120	130	140	150	160	170	180
CAS - MPH	70	77	85	94	103	111	120	129	138	147	157	166	175
Flaps 40°													
IAS - MPH	60	70	80	90	100	110	120						
CAS - MPH	67	74	82	91	100	109	118						

### MOORINGS

The Cherokee Arrow II should be moved on the ground with the aid of the nose wheel tow bar provided with each plane and secured in the baggage compartment. Tie down ropes may be secured to rings provided under each wing and to the tail skid. The aileron and stabilator control should be secured by looping the seat belt through the control wheel and pulling it snug. The rudder is held in position by its connections to the nose wheel steering and normally does not have to be secured. The flaps are locked when in the full up position and should be left retracted.

### WEIGHT AND BALANCE

It is the responsibility of the pilot to determine that the airplane remains within the allowable weight vs. center of gravity envelope while in flight. For weight and balance data see the Airplane Flight Manual and Weight and Balance form supplied with each airplane.

### EMERGENCY LOCATOR TRANSMITTER\*

The Emergency Locator Transmitter (ELT) when installed, is located in the aft portion of the fuselage just below the stabilator leading edge and is accessible through a plate on the right side of the fuselage. (On aircraft manufactured prior to mid-1975, this plate is retained by three steel Phillips head screws. On aircraft manufactured from mid-1975 and on, this plate is attached with three slotted-head nylon screws for ease of removal; these screws may be readily removed with a variety of common items such as a dime, a key, a knife blade, etc. If there are no tools available in an emergency the screw heads may be broken off by any means.) It is an emergency locator transmitter which meets the requirements of FAR 91.52. The unit operates on a self-contained battery.

\*Optional equipment

A battery replacement date is marked on the transmitter label. To comply with FAA regulations, the battery must be replaced on or before this date. The battery must also be replaced if the transmitter has been used in an emergency situation or if the accumulated test time exceeds one hour, or if the unit has been inadvertently activated for an undetermined time period.

On the unit itself is a three position selector switch labeled "OFF," "ARM" and "ON." The "ARM" position is provided to set the unit to the automatic position so that it will transmit only after impact and will continue to transmit until the battery is drained to depletion or until the switch is manually moved to the "OFF" position. The "ARM" position is selected when the transmitter is installed at the factory and the switch should remain in that position whenever the unit is installed in the airplane. The "ON" position is provided so the unit can be used as a portable transmitter or in the event the automatic feature was not triggered by impact or to periodically test the function of the transmitter.

Select the "OFF" position when changing the battery, when rearming the unit if it has been activated for any reason, or to discontinue transmission.

#### NOTE

If the switch has been placed in the "ON" position for any reason, the "OFF" position has to be selected before selecting "ARM." If "ARM" is selected directly from the "ON" position, the unit will continue to transmit in the "ARM" position.

A pilot's remote switch, located on the left side panel, is provided to allow the transmitter to be controlled from inside the cabin.

1. On some models the pilot's remote switch has three positions and is placarded "ON," "AUTO/ARM," and "OFF/RESET." The switch is normally left in the "AUTO/ARM" position. To turn the transmitter off, move the switch momentarily to the "OFF/RESET" position. The aircraft master switch must be "ON" to turn the transmitter "OFF." To activate the transmitter for tests or other reasons, move the switch upward to the "ON" position and leave it in that position as long as transmission is desired.
2. On other models the pilot's remote switch has two positions and is placarded "ON/RESET" and "ARM (NORMAL POSITION)." The switch is normally left in the down or "ARM" position. To turn the transmitter off, move the switch to the "ON/RESET" position for one second then return it to the "ARM" position. To activate the transmitter for tests or other reasons, move the switch upward to the "ON/RESET" position and leave it in that position as long as transmission is desired.

The locator should be checked during the ground check to make certain the unit has not been accidentally activated. Check by tuning a radio receiver to 121.5 MHz. If there is an oscillating sound, the locator may have been activated and should be turned off immediately. Reset to the "ARM" position and check again to insure against outside interference.

**NOTE**

If for any reason a test transmission is necessary, the test transmission should be conducted only in the first five minutes of any hour and limited to three audio sweeps. If tests must be made at any other time, the tests should be coordinated with the nearest FAA tower or flight service station.

**AIR CONDITIONING \***

To operate the air conditioning system either on the ground or in flight:

1. Start the engine (ground operation).
2. Turn the air conditioning "Master" switch to "ON."
3. Turn "TEMP" control to desired temperature. Clockwise rotation increases cooling.
4. Select desired "FAN" position, "LOW," "MED" or "HIGH."

**AIR CONDITIONER OPERATIONAL CHECK PROCEDURE**

Prior to take-off the air conditioner should be checked for proper operation as follows:

1. Check aircraft Master Switch ON.
2. Select desired "FAN" position, "LOW," "MED" or "HIGH."
3. Turn the air conditioner control switch to "ON" - the "Air Cond. Door Open" warning light will turn on, thereby indicating proper air conditioner condenser door actuation.
4. Turn the air conditioner control switch to "OFF" - the "Air Cond. Door Open" warning light will go out, thereby indicating the air conditioner condenser door is in the up position.
5. If the "Air Cond. Door Open" light does not respond as specified above, an air conditioner system or indicator bulb malfunction is indicated, and further investigation should be conducted prior to flight.

The above operational check may be performed during flight if an inflight failure is suspected.

**AIR CONDITIONER EFFECTS ON AIRPLANE PERFORMANCE**

Operation of the air conditioner will cause slight decreases in the cruise speed and range of the Cherokee Arrow II. Power from the engine is required to run the compressor, and the condenser door, when extended, causes a slight increase in drag. When the air conditioner is turned off there is normally no measurable difference in climb, cruise or range performance of the airplane.

**NOTE**

To insure maximum climb performance the air conditioner must be turned off manually before take-off to disengage the compressor and retract the condenser door. Also the air conditioner must be turned off manually before the landing approach in preparation for a possible go-around.

\*Optional equipment

---

Although the cruise speed and range are only slightly affected by the air conditioner operation, these changes should be considered in preflight planning. To be conservative, the following figures assume that the compressor is operating continuously while the airplane is airborne. This will be the case only in extremely hot weather.

1. Decrease true airspeed - approximately 5 mph at normal cruise power setting.
2. Decrease range - may be as much as 30 statute miles for 48 gallon capacity.

When the full throttle is not used or in the event of malfunction which caused the compressor to operate and the condenser door to be extended, a decrease in rate of climb of as much as 100 feet per minute can be expected. Should a malfunction occur which prevents the condenser door retraction when the compressor is turned off, a decrease in rate of climb of as much as 50 feet per minute can be expected.



# OPERATING TIPS

Operating Tips ..... 8-1

BLANK PAGE

OPERATING TIPS

Operating this equipment requires a minimum of two persons.

---

## OPERATING TIPS

The following Operating Tips are of particular value in the operation of the Cherokee Arrow II.

1. Learn to trim for takeoff so that only a very light back pressure on the wheel is required to lift the airplane off the ground.
2. On takeoff, do not retract the gear prematurely. The airplane may settle and make contact with the ground because of lack of flying speed, atmospheric conditions, or rolling terrain.
3. The best speed for takeoff is about 65 MPH under normal conditions. Trying to pull the airplane off the ground at too low an airspeed decreases the controllability of the airplane in event of engine failure.
4. In high density areas where high traffic pattern speeds are necessary or when it is advantageous to extend the gear, it is permissible to extend the landing gear at speeds up to 150 MPH.
5. Flaps may be lowered at airspeeds up to 125 MPH. To reduce flap operating loads, it is desirable to have the airplane at a slower speed before extending the flaps.
6. Before attempting to reset any circuit breaker, allow a two to five minute cooling off period.
7. Always determine position of landing gear by checking the gear position lights.
8. Remember that when the panel lights are on, the gear position lights are very dim.
9. Before starting the engine, check that all radio switches, light switches, and the pilot heat switch are in the off position so as not to create an overloaded condition when the starter is engaged.
10. A high fuel pressure indication on the fuel flow indicator is a possible sign of restricted air bleed nozzles.
11. The overvoltage relay is provided to protect the electronics equipment from a momentary overvoltage condition (approximately 16.5 volts and up), or a catastrophic regulator failure. In event of a momentary condition, the relay will open and the ammeter will indicate zero output from the alternator. The relay may be reset by switching the "ALT" switch "OFF" for approximately 30 seconds and then returning the "ALT" switch to "ON". If after recycling the "ALT" switch the condition persists, the flight should be terminated as soon as practical. Reduce the battery load to a minimum. The ALT light on the annunciator panel\* will illuminate if the alternator fails. Recycle the ALT switch and check the ALT FIELD circuit breaker. If the failure persists after this action, reduce electrical loads and land as soon as practical.
12. On aircraft equipped with the backup gear extender, it should always be kept in mind that the system is intended to lower the gear during the approach should the pilot forget. However, the pilot should always lower the gear during normal operations by using the gear selector switch on the instrument panel.

\*Serial nos. 7535001 and up.

13. The vacuum gauge is provided to monitor the pressure available to assure the correct operating speed of the vacuum-driven gyroscopic flight instruments. It also monitors the condition of the common air filter by measuring the flow of air through the filter.

If the vacuum gauge does not register 5" Hg  $\pm$  .10" Hg at 2000 RPM, the following items should be checked before flight:

- a. Common air filter, could be dirty or restricted.
  - b. Vacuum lines, could be collapsed or broken.
  - c. Vacuum pump, worn.
  - d. Vacuum regulator, not adjusted correctly. The pressure, even though set correctly, can read lower under two conditions:
    - (1) Very high altitude, above 12,000 feet.
    - (2) Low engine RPM usually on approach or during training maneuvers.  
This is normal and should not be considered a malfunction.
14. The shape of the wing fuel tanks is such that in certain maneuvers the fuel may move away from the tank outlet. If the outlet is uncovered, the fuel will be interrupted and a temporary loss of power may result. Pilots can prevent inadvertent uncovering of the outlet by avoiding maneuvers which could result in uncovering the outlet.

Extreme running turning takeoffs should be avoided as fuel flow interruption may occur.

Prolonged slips or skids which result in excess of 2000 feet of altitude loss, or other radical or extreme maneuvers which could cause uncovering of the fuel outlet must be avoided as fuel flow interruption may occur when tank being used is not full.
  15. The rudder pedals are suspended from a torque tube which extends across the fuselage. The pilot should become familiar with the proper positioning of his feet on the rudder pedals so as to avoid interference with the torque tube when moving the rudder pedals or operating the toe brakes.
  16. Anti-collision lights should not be operating when flying through overcast and clouds, since reflected light can produce spacial disorientation. Do not operate strobe lights when taxiing in the vicinity of other aircraft.
  17. In an effort to avoid accidents, pilots should obtain and study the safety related information made available in FAA publications such as regulations, advisory circulars, Aviations News, AIM and safety aids.

# PERFORMANCE CHARTS

Altitude Conversion Chart .....	9-1
Takeoff Performance .....	9-2
Climb Performance.....	9-3
Cruise Performance - True Airspeed .....	9-4
Cruise Performance - Range .....	9-5
Stalling Speed vs Angle of Bank .....	9-6
Stalling Speed vs Weight .....	9-7
Glide Performance.....	9-8
Landing Performance .....	9-9
Power Setting Table.....	9-10

## WARNING

Performance information derived by extrapolation beyond the limits shown on the charts should not be used for flight planning purposes.

BLANK PAGE

PERFORMANCE CHARTS

0.1	...	...
0.2	...	...
0.3	...	...
0.4	...	...
0.5	...	...
0.6	...	...
0.7	...	...
0.8	...	...
0.9	...	...
1.0	...	...

WARNING

Performance charts are for informational purposes only. They should not be used for flight planning.

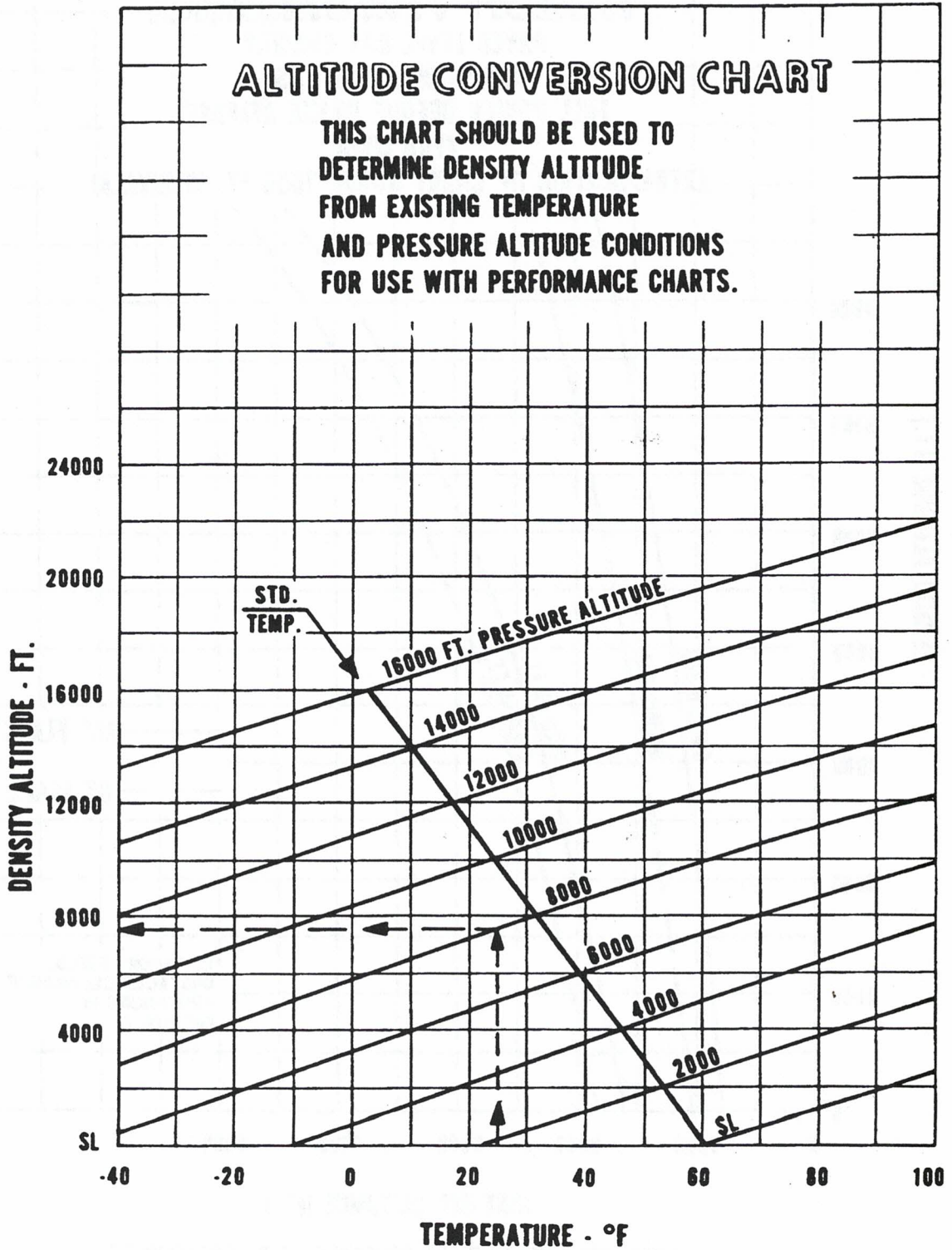

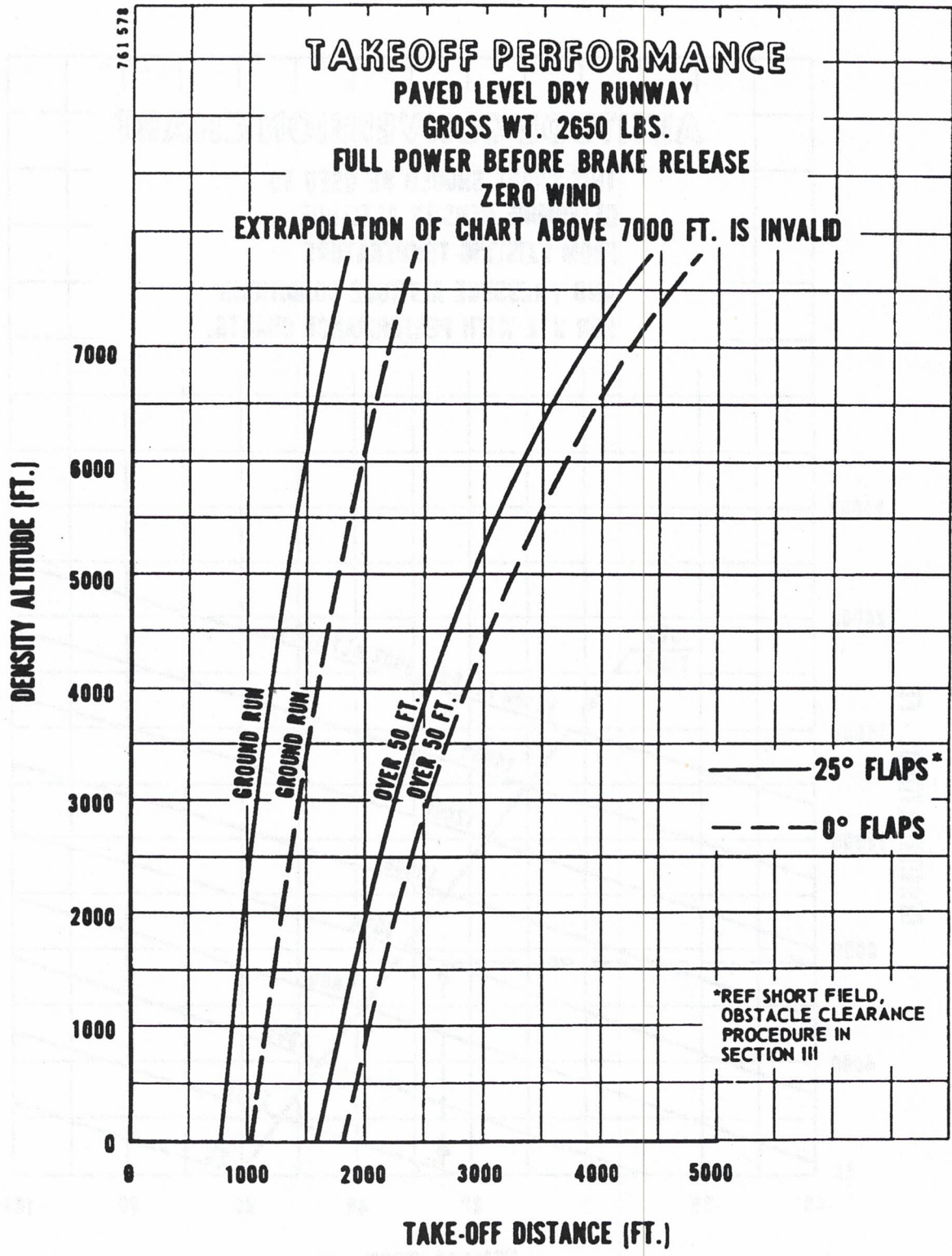

NOTE: SEE SECTION 7 FOR EFFECTS OF AIR CONDITIONING INSTALLATION ON PERFORMANCE.

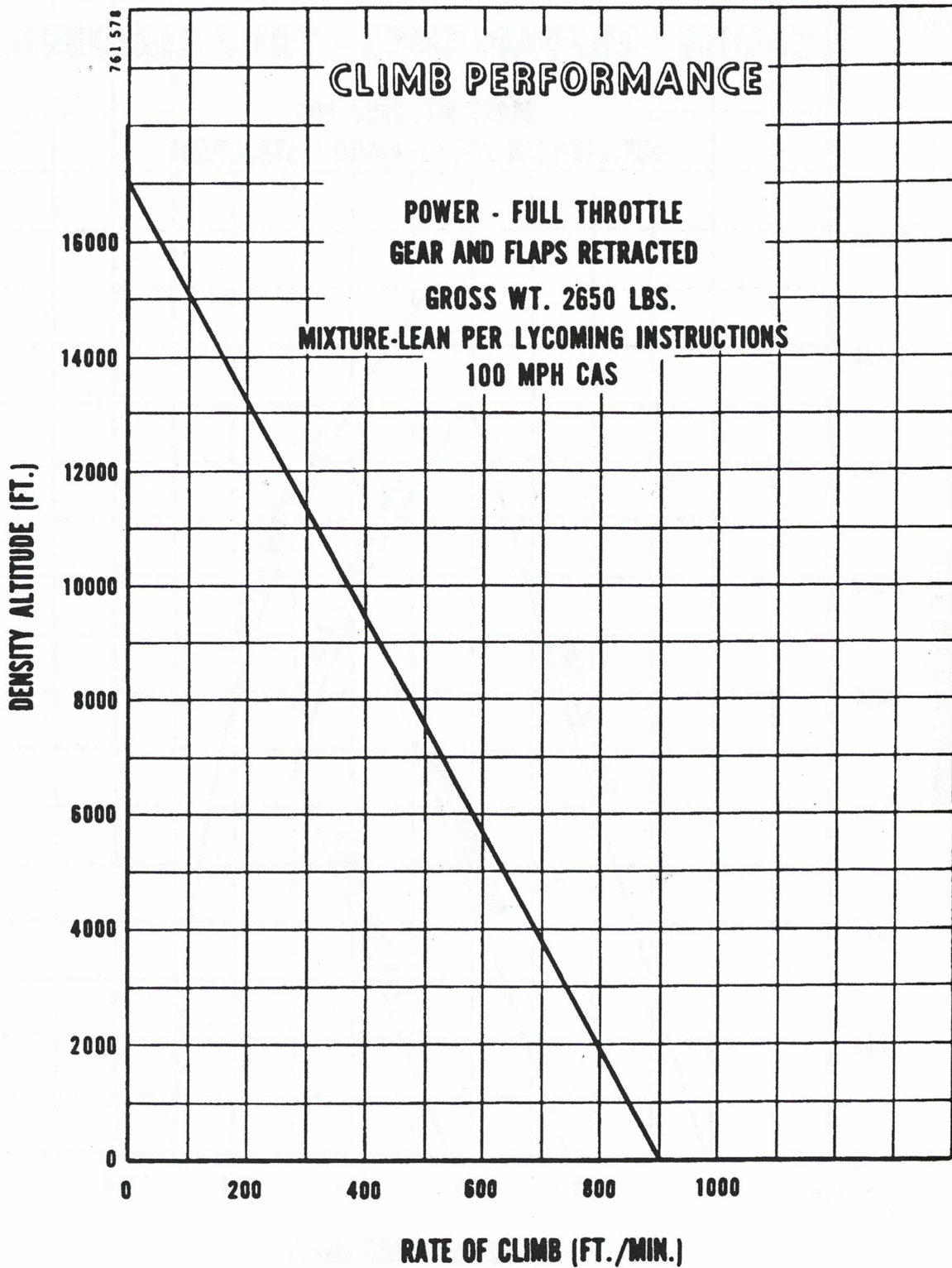

NOTE: SEE SECTION 7 FOR EFFECTS OF AIR CONDITIONING  
INSTALLATION ON PERFORMANCE.

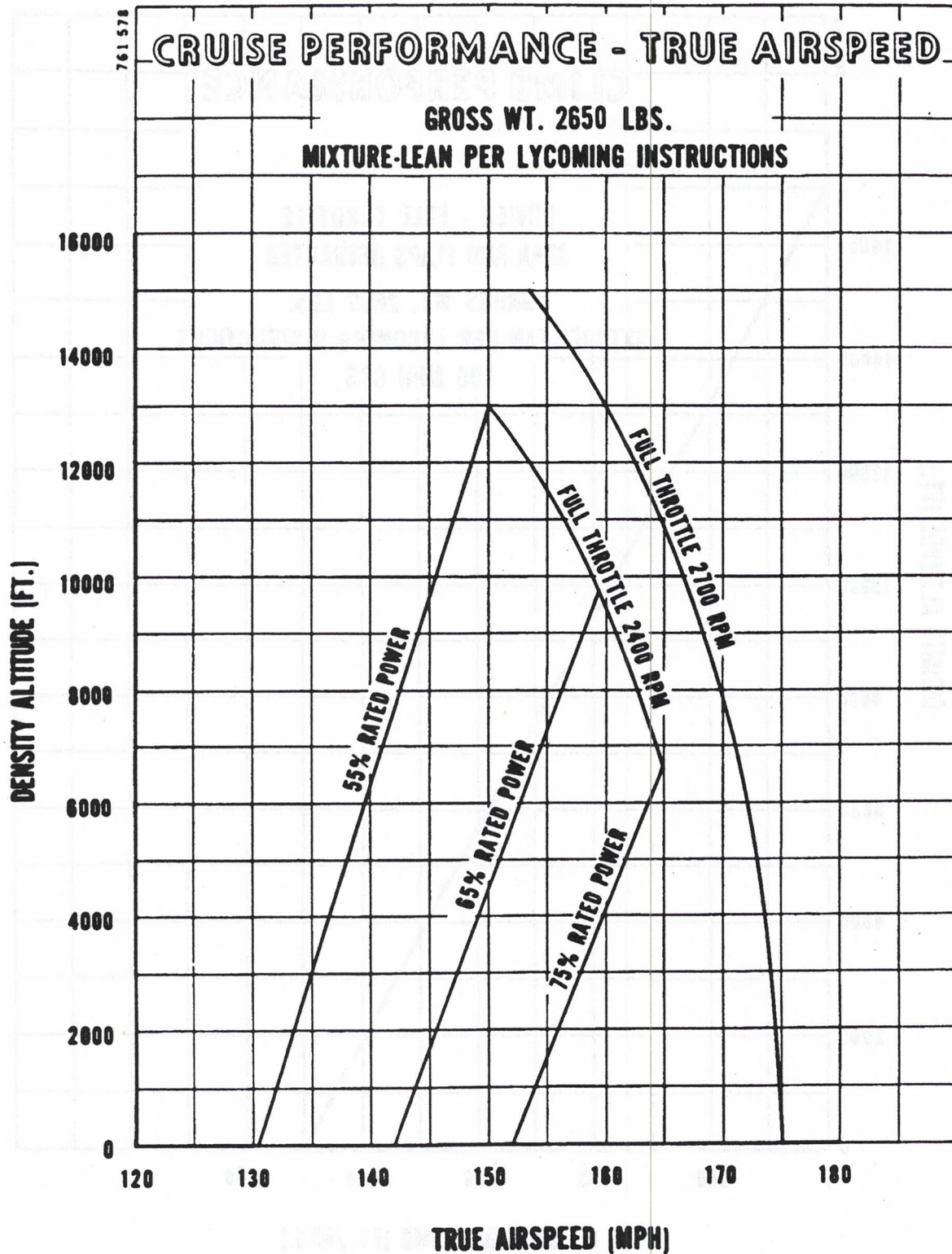

NOTE: SEE SECTION 7 FOR EFFECTS OF AIR CONDITIONING INSTALLATION ON PERFORMANCE.

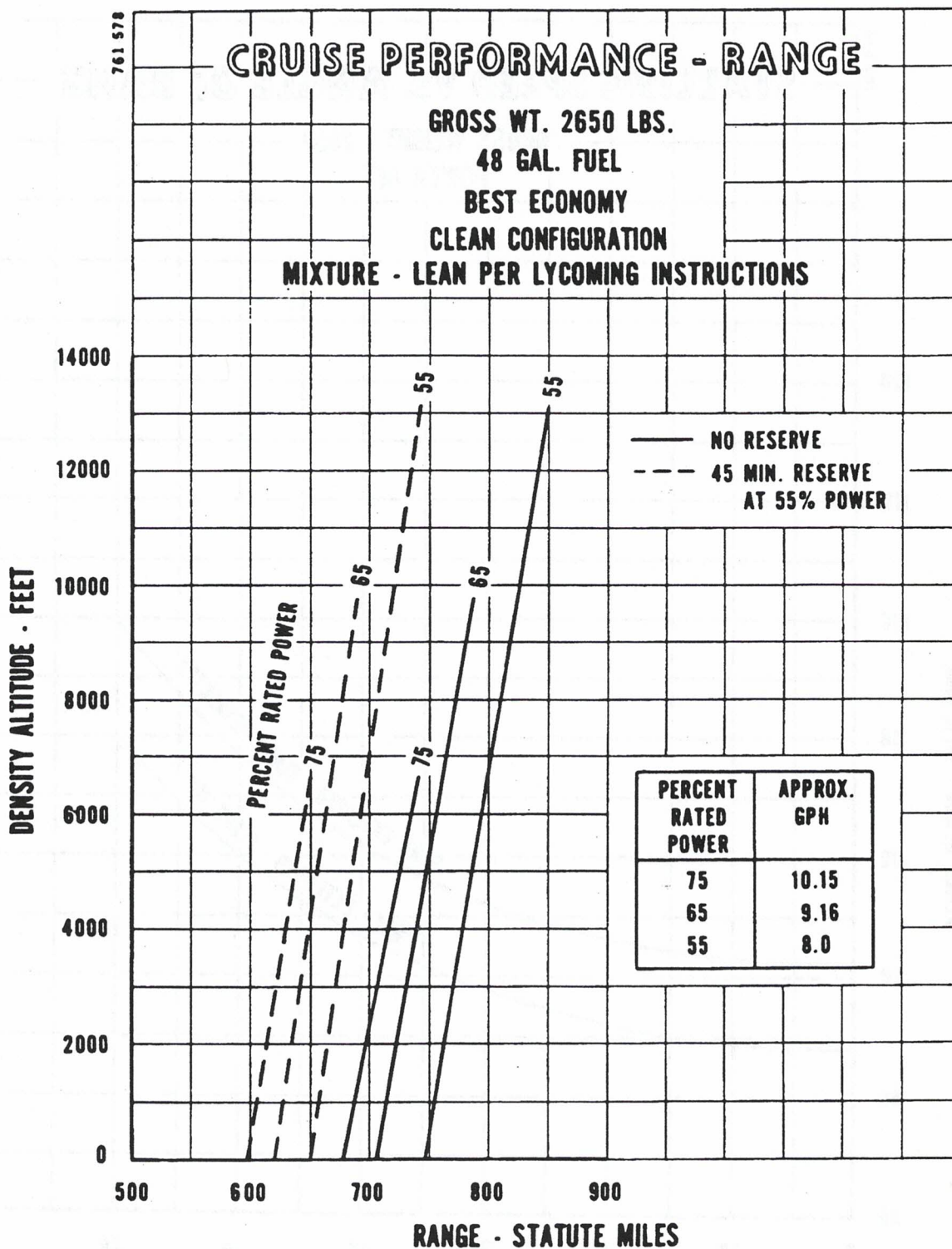

NOTE: SEE SECTION 7 FOR EFFECTS OF AIR CONDITIONING  
INSTALLATION ON PERFORMANCE.

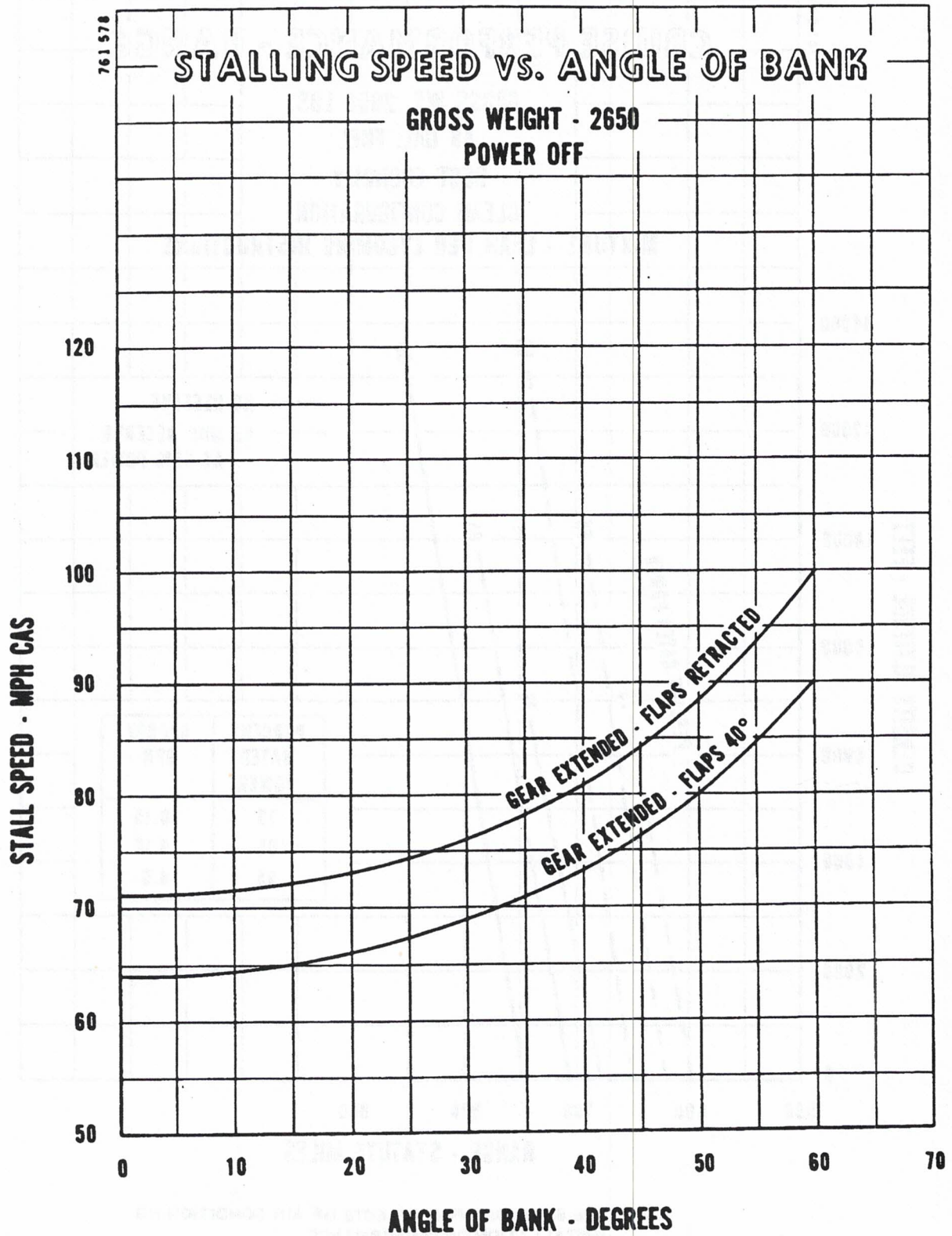

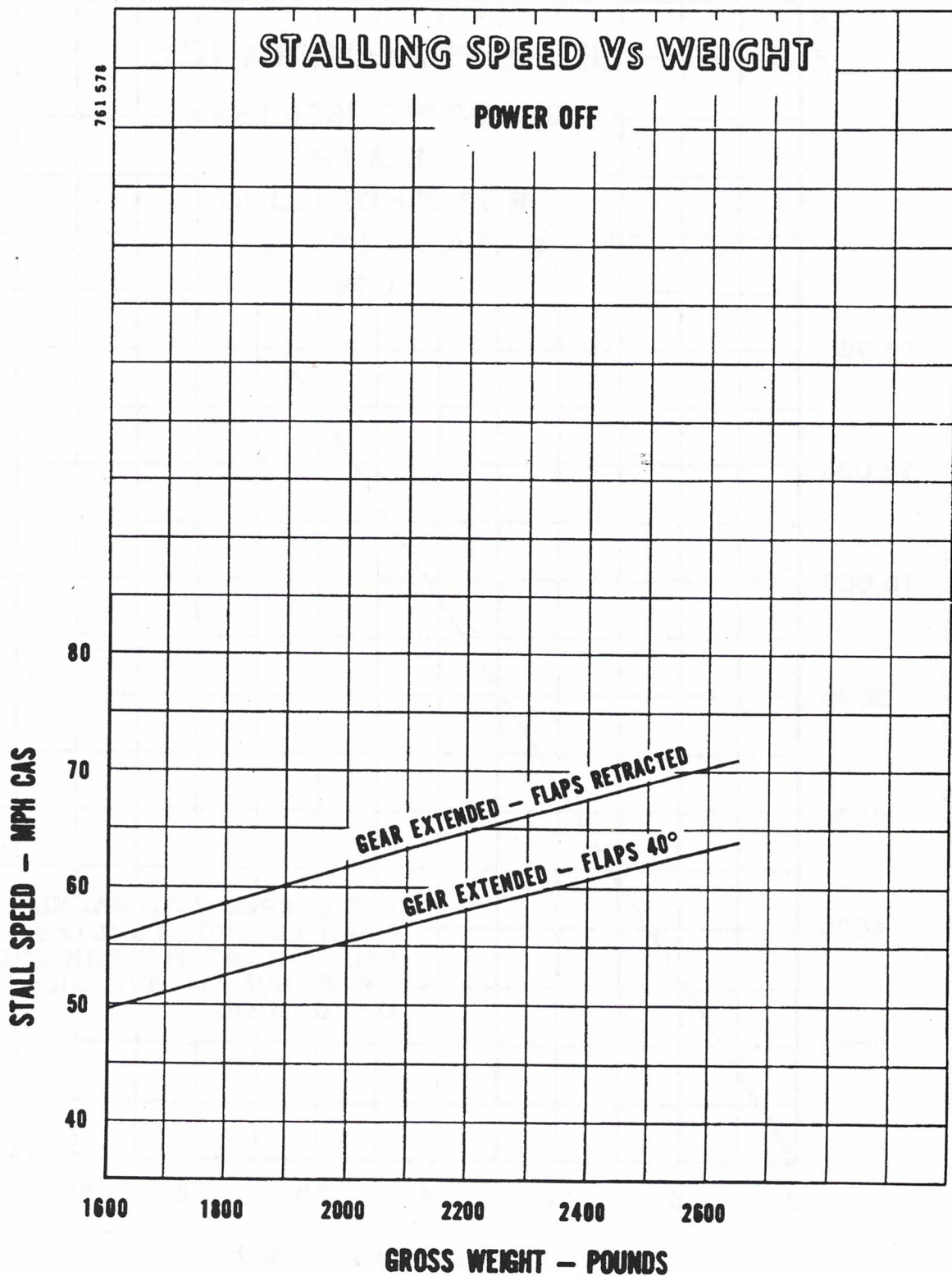

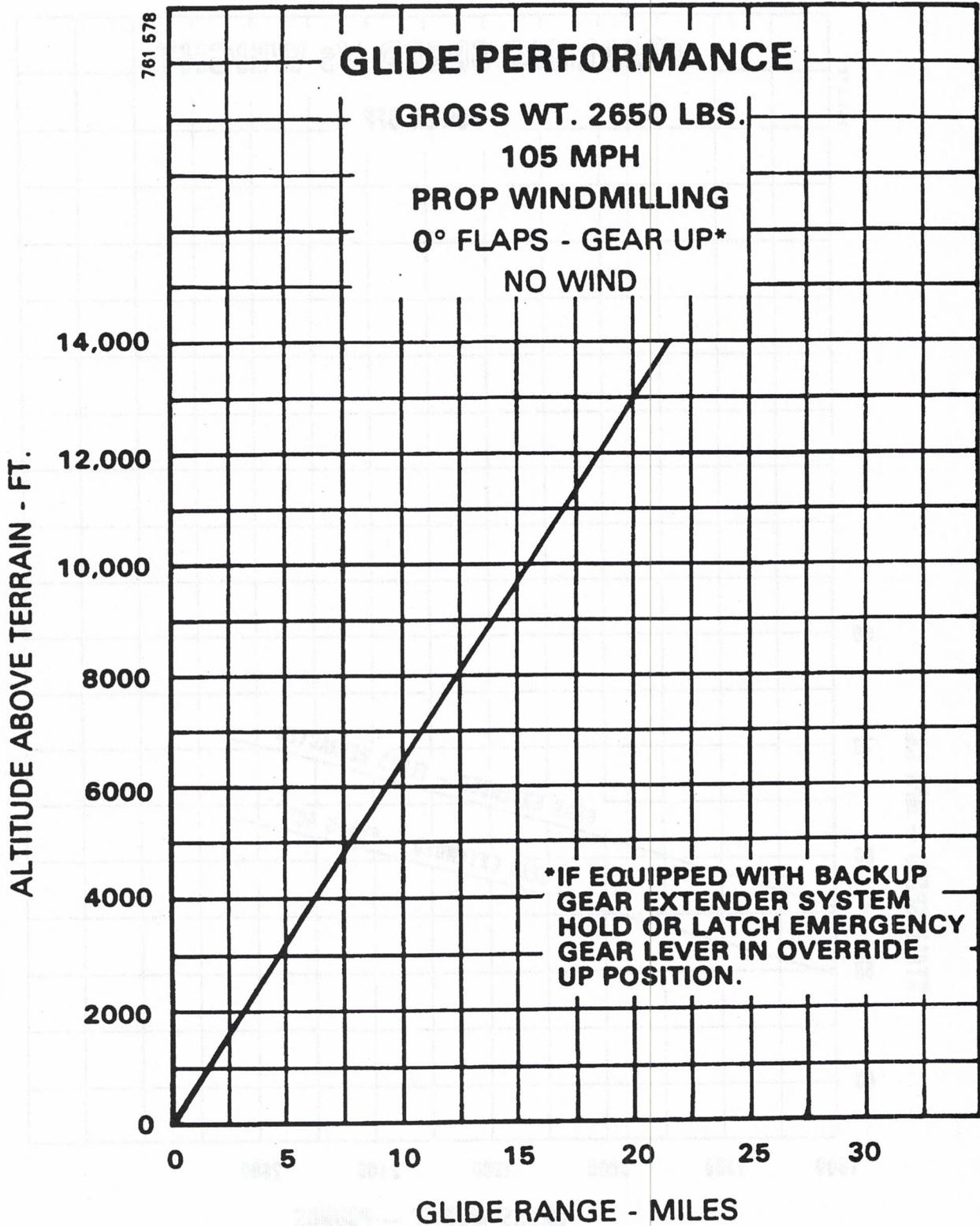

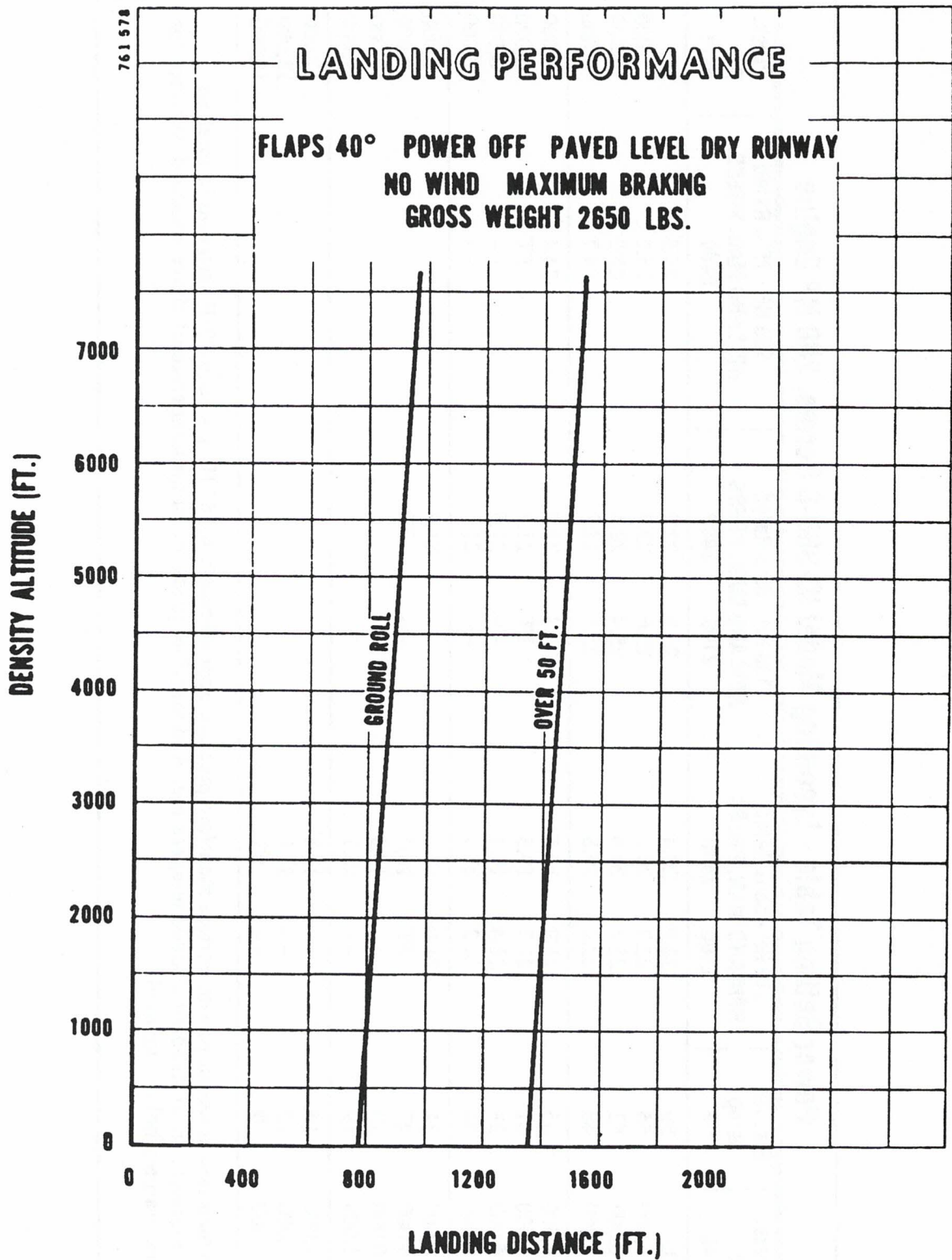

NOTE: SEE SECTION 7 FOR EFFECTS OF AIR CONDITIONING INSTALLATION ON PERFORMANCE.

**Power Setting Table - Lycoming Model IO-360-C Series, 200 HP Engine**

Press. Alt Feet	Std. Alt Temp ° F	110 HP - 55% Rated RPM AND MAN. PRESS.		130 HP - 65% Rated RPM AND MAN. PRESS.		150 HP - 75% Rated RPM AND MAN. PRESS.		Press. Alt Feet
		2100	2400	2100	2400	2100	2400	
SL	59	22.9	20.4	25.9	22.9	25.5	24.4	SL
1,000	55	22.7	20.2	25.6	22.7	25.2	24.4	1,000
2,000	52	22.4	20.0	25.4	22.5	25.0	24.4	2,000
3,000	48	22.2	19.8	25.1	22.2	24.7	24.4	3,000
4,000	45	21.9	19.5	24.8	22.0	24.4	24.4	4,000
5,000	41	21.7	19.3	FT	21.7	FT	24.4	5,000
6,000	38	21.4	19.1	--	21.5	--	24.4	6,000
7,000	34	21.2	18.9	--	21.3	--	24.4	7,000
8,000	31	21.0	18.7	--	21.0	--	24.4	8,000
9,000	27	FT	18.5	--	FT	--	24.4	9,000
10,000	23	--	18.3	--	--	--	24.4	10,000
11,000	19	--	18.1	--	--	--	24.4	11,000
12,000	16	--	17.8	--	--	--	24.4	12,000
13,000	12	--	17.6	--	--	--	24.4	13,000
14,000	9	--	FT	--	--	--	24.4	14,000

To maintain constant power, correct manifold pressure approximately 0.16" Hg for each 10°F variation in inlet air temperature from standard altitude temperature. Add manifold pressure for air temperatures above standard; subtract for temperatures below standard.

# HANDLING AND SERVICING

Ground Handling .....	10-1
Towing .....	10-1
Taxiing .....	10-1
Parking .....	10-2
Mooring.....	10-2
Cleaning.....	10-3
Cleaning Engine Compartment.....	10-3
Cleaning Landing Gear .....	10-3
Cleaning Exterior Surfaces .....	10-4
Cleaning Windshield and Windows.....	10-4
Cleaning Headliner, Side Panels and Seats.....	10-4
Cleaning Carpets.....	10-4
Power Plant Induction Air Filter .....	10-5
Removal of Induction Air Filter .....	10-5
Cleaning Induction Air Filter.....	10-5
Installation of Induction Air Filter.....	10-5
Brake Service.....	10-5
Landing Gear Service .....	10-6
Propeller Service.....	10-7
Oil Requirements .....	10-7
Fuel System .....	10-7
Fuel Requirements .....	10-7
Filling Fuel Tanks .....	10-8
Draining Fuel Valves and Lines.....	10-8
Draining Fuel System .....	10-8
Tire Inflation.....	10-9
Battery Service .....	10-9
Winterization .....	10-9
Facts You Should Know .....	10-11
Preventive Maintenance .....	10-12
Required Service and Inspection Periods .....	10-13

BLANK PAGE

---

## HANDLING AND SERVICING

This section contains information on preventive maintenance. Refer to the appropriate Service Manual for further maintenance procedures. Any complex repair or modification should be accomplished by a Piper Certified Service Center.

### GROUND HANDLING

#### TOWING

The airplane may be moved by using the nose wheel steering bar provided, or power equipment that will not damage or cause excess strain to the nose gear assembly. The steering bar is stowed in the baggage compartment.

#### CAUTION

When towing with power equipment, do not turn nose gear more than 30 degrees in either direction as this will result in damage to the nose gear and steering mechanism.

#### TAXIING

Before attempting to taxi the airplane, ground personnel should be checked out by a qualified pilot or other responsible person. Engine starting and shut-down procedures should be covered as well as taxi techniques. When it is ascertained that the propeller back blast and taxi areas are clear, power should be applied to start the taxi roll and the following checks should be performed.

- a. Taxi forward a few feet and apply brakes to determine their effectiveness.
- b. Taxi with propeller set in low pitch, high RPM setting.
- c. While taxiing, make slight turns to ascertain the effectiveness of steering.
- d. Observe wing clearances when taxiing near buildings or other stationary objects. If possible, station a guide outside the airplane to observe.
- e. When taxiing on uneven ground, look for holes and ruts.
- f. Do not operate the engine at high RPM when running up or taxiing over ground containing loose stones, gravel or any loose material that may cause damage to the propeller blades.

## ARROW II

---

### PARKING

When parking the airplane, insure that it is sufficiently protected against adverse weather conditions and presents no danger to other aircraft. When parking the airplane for any length of time or overnight, it is recommended that it be moored securely.

- a. To park the airplane, head it into the wind, if possible.
- b. Set the parking brake. (Use wheel chocks if available.)

### NOTE

Care should be taken to avoid setting brakes that are overheated or during cold eather when accumulated moisture may freeze a brake.

### MOORING

The airplane should be moored to insure its immovability, protection and security under varying weather conditions. The following procedure should be used for proper mooring of the airplane.

- a. Head the airplane into the wind, if possible.
- b. Lock the aileron and stabilator controls by looping the seat belt through the control wheel and pulling it snug.
- c. Block the wheels.
- d. Secure tie down ropes to the wing tie down rings and tail skid at approximately 45-degree angles to the ground.

### CAUTION

Use bowline knots or locked slip knot. Do not use a plain slip knot.

### NOTE

Additional preparations for high winds include using tie down ropes from the landing gear forks, and securing the rudder.

---

## CLEANING

### CLEANING ENGINE COMPARTMENT

Before cleaning the engine compartment, place a strip of tape on the magneto vents to prevent solvent from entering these units.

- a. Place a large pan under the engine to catch waste.
- b. With the engine cowling removed, spray or brush the engine with solvent or a mixture of solvent and degreaser, as desired. Where heavy grease and dirt deposits have collected, it may be necessary to brush areas that were sprayed, in order to clean them.

#### CAUTION

Do not spray solvent into the alternator, vacuum pump, starter or air intakes.

- c. Allow the solvent to remain on the engine from five to ten minutes. Then rinse the engine clean with additional solvent and allow to dry.

#### CAUTION

Do not operate engine until excess solvent has evaporated or otherwise been removed.

- d. Remove the protective covers from the magnetos.
- e. Lubricate controls, bearing surfaces, etc., in accordance with the Lubrication Chart.

### CLEANING LANDING GEAR

Before cleaning the landing gear, place a plastic cover or similar material over the wheel and brake assembly.

- a. Place a pan under the gear to catch waste.
- b. Spray or brush the gear area with solvent or a mixture of solvent and degreaser, as desired. Where heavy grease and dirt deposits have collected, it may be necessary to brush areas that were sprayed, in order to clean them.
- c. Allow the solvent to remain on the gear from five to ten minutes. Then rinse the gear with additional solvent and allow to dry.
- d. Remove the cover from the wheel and remove the catch pan.
- e. Lubricate the gear in accordance with the Lubrication Chart.
- f. Caution: Do not brush the micro switches.

**CLEANING EXTERIOR SURFACES**

The airplane should be washed with a mild soap and water. Harsh abrasive or alkaline soaps or detergents used on painted or plastic surfaces could make scratches or cause corrosion of metal surfaces. Cover areas where cleaning solution could cause damage. To wash the airplane, the following procedure may be used:

- a. Flush away loose dirt with water.
- b. Apply cleaning solution with a rag, sponge or soft bristle brush.
- c. To remove stubborn oil and grease, use a cloth dampened with naphtha.
- d. Where exhaust stains exist, allow solution to remain on the surface longer.
- e. Any good automotive wax may be used to preserve the painted surfaces. Soft cleaning cloths or a chamois should be used to prevent scratches when cleaning or polishing. A heavier coating of wax on the leading surfaces will reduce the abrasion problems in these areas.

**CLEANING WINDSHIELD AND WINDOWS**

- a. Remove dirt, mud, and other marks from exterior surface with clean water.
- b. Wash with mild soap and warm water or an aircraft plastic cleaner. Use a soft cloth or sponge using a straight rubbing motion. Do not rub surface harshly.
- c. Remove oil and grease with a cloth moistened with kerosene.

**NOTE**

Do not use gasoline, alcohol, benzene, carbon tetrachloride, thinner, acetone, or window cleaning sprays.

- d. After cleaning plastic surfaces, apply a thin coat of hard polishing wax. Rub lightly with a soft cloth. Do not use a circular motion.
- e. A severe scratch or mar in plastic can be removed by using jeweler's rouge to rub out the scratch. Smooth both sides and apply wax.

**CLEANING HEADLINER, SIDE PANELS AND SEATS**

- a. Clean headliner, side panels and seats with a stiff bristle brush, and vacuum where necessary.
- b. Soiled upholstery, except leather, may be cleaned by using an approved foam upholstery cleaner. Carefully follow the manufacturer's instructions. Avoid soaking or harsh rubbing.

**CAUTION**

Solvent cleaners require adequate ventilation.

**CLEANING CARPETS**

Use a small whisk broom or vacuum cleaner to remove dirt. For soiled spots, use a non-flammable dry cleaning fluid.

---

## POWER PLANT INDUCTION AIR FILTER

The induction air filters must be cleaned at least once every 50 hours. Depending on the type of condition existing, it may be necessary to clean the filters more often.

### REMOVAL OF INDUCTION AIR FILTER

- a. Remove top cowl.
- b. Remove the thumb screws holding the filter cover.
- c. Remove filter.

### CLEANING INDUCTION AIR FILTER

- a. Tap filter gently to remove dirt particles. Do not use compressed air or cleaning solvents.
- b. Inspect filter. If paper element is torn or ruptured or gasket is damaged, the filter should be replaced. The usable life of the filter should be restricted to one year or 500 hours, whichever comes first.

### INSTALLATION OF INDUCTION AIR FILTER

- a. After cleaning or replacing filter, install filter in reverse order of removal.

## BRAKE SERVICE

The brake system is filled with MIL-H-5606 (petroleum base), red hydraulic brake fluid. This should be checked periodically or at every 100-hour inspection and replenished when necessary. The brake reservoir is located in the upper left corner of the front side of the firewall. Keep the fluid level at the level marked on the reservoir.

No adjustment of brake clearance is necessary. Refer to the Service Manual for the procedure for replacing brake linings.

## ARROW II

---

### LANDING GEAR SERVICE

The main landing gear uses Cleveland Aircraft Products wheels and Cleveland single disc hydraulic brake assemblies. The main wheel tires are 6.00 x 6, four-ply rating, type III with tubes. The nose wheel uses a Cleveland Aircraft Products 5.00 wheel with a 5.00 x 5, four-ply rating, type III tire with tube.

Wheels are removed by taking off the hub cap, cotter pin, axle nut, and the two bolts holding the brake segment in place. Mark tire and wheel for reinstallation; then dismount by deflating the tire, removing the three through-bolts from the wheel and separating the wheel halves.

Landing gear oleos on the Cherokee Arrow should be serviced according to the instructions on the units. The main oleos should be extended under normal static load until  $2.0 \pm .25$  inches of oleo piston tube is exposed, and the nose gear should show  $2.75 \pm .25$  inches. To add air to the oleo struts, attach a strut pump to the valve assembly near the top of the oleo strut housing and pump the oleo to the desired position. To add oil, jack the aircraft, release the air pressure in the strut, remove the valve core and add oil through this opening with the strut extended. After the strut is full, compress it slowly and fully to allow excess air and oil to escape. With the strut still compressed reinsert the valve stem and pump up the strut as above.

In jacking the aircraft for landing gear or other service, two hydraulic jacks and a tail stand should be used. At least 250 pounds of ballast should be placed on the base of the tail stand before the airplane is jacked up. The hydraulic jacks should be placed under the jack points on the bottom of the wing and the airplane jacked up until the tail skid is at the right height to attach the tail stand. After the tail stand is attached and the ballast added, jacking may be continued until the airplane is at the height desired. There is also a jack point behind the nose gear actuating cylinder.

The steering arms from the rudder pedals to the nose wheel are adjusted at the rudder pedals or at the nose wheel by turning the threaded rod end bearings in or out. Adjustment is normally accomplished at the forward end of the rods and should be done in such a way that the nose wheel is in line with the fore and aft axis of the plane when the rudder pedals and rudder are centered. Alignment of the nose wheel can be checked by pushing the airplane back and forth with the rudder centered to determine that the plane follows a perfectly straight line. The turning arc of the nose wheel is 30 degrees in either direction and is factory adjusted at stops on the bottom of the forging. The turning radius of the nose wheel is 13 feet.

The steering arm stops should be carefully adjusted so that the nose wheel reaches its full travel just after the rudder hits its stops. This guarantees that the rudder will be allowed to move through its full travel.

## PROPELLER SERVICE

The spinner and backing plate should be cleaned and inspected frequently for cracks. The propeller should be inspected before each flight for nicks, scratches, and corrosion. If found, they should be taken care of as soon as possible by a rated mechanic, because nicks and scratches cause areas of increased stress which can cause serious damage or loss of a propeller tip. The back face of the blades should be painted when necessary with flat black paint to retard glare to the pilot's eyes. To prevent corrosion the surface should be cleaned and waxed periodically.

## OIL REQUIREMENTS

The oil capacity of the Lycoming engine is 8 quarts with a minimum safe quantity of 2 quarts. It is recommended that engine oil be drained and renewed every 50 hours. The oil filter element should be changed every 50 hours of operation. The interval between oil and oil filter changes should not exceed a total of four months. Under unfavorable dusty conditions, the oil and oil filter should be changed more frequently. Should fuel other than the specified octane rating for the power plant be used, refer to the latest issue of Lycoming Service Letter No. L185 for additional information and recommended service procedures.

The following seasonal aviation oil grades and seasonal ambient temperature ranges are recommended.

Average Ambient Temperature	MIL-L-6082B Mineral SAE Grade	MIL-L-22851 Ashless Dispersant SAE Grades
All Temperatures	--	15W-50 or 20W-50
Above 80°F	60	60
Above 60°F	50	40 or 50
30°F to 90°F	40	40
0°F to 70°F	30	30, 40 or 20W-40
0°F to 90°F	20W-50	20W-50 or 15W-50
Below 10°F	20	30 or 20W-30

When operating temperatures overlap indicated ranges, use the lighter grade oil.

### NOTE

Refer to the latest issue of Textron Lycoming Service Instruction 1014 (Lubricating Oil Recommendations) for further information.

## FUEL SYSTEM

The fuel screens in the strainer and the injector will require cleaning every 50 hour inspection. The screen in the injector is located in the housing where the fuel inlet line connects to the injector. The fuel strainer, located ahead of the firewall, is accessible for cleaning by removal of the lower cowl. When the strainers are reassembled after cleaning, a small amount of grease applied to the gasket will facilitate assembly.

### FUEL REQUIREMENTS (AVGAS ONLY)

A minimum octane of 100/130 Aviation Grade fuel must be used in the Arrow II. Since the use of lower grades can cause serious engine damage in a short period of time, the engine warranty is invalidated by the use of lower octanes.

## ARROW II

---

The operation of the aircraft is approved with an anti-icing additive in the fuel. When an anti-icing additive is used, it must meet the specification MIL-I-27686, must be uniformly blended with the fuel while refueling, must not exceed .15% by volume of the refueled quantity, and to ensure its effectiveness, should be blended at not less than .10% by volume. One and one half liquid ozs. per ten gallons of fuel would fall within this range. A blender supplied by the additive manufacturer should be used. Except for the information contained in this section, the manufacturer's mixing or blending instructions should be carefully followed.

### CAUTIONS

Some fuels have anti-icing additives preblended in the fuel at the refinery, so no further blending should be performed.

Fuel additive cannot be used as a substitute for preflight draining of the fuel system.

### FILLING FUEL TANKS

Observe all required precautions for handling gasoline. Fill the fuel tanks to the bottom of the filler neck. Each wing tank holds a maximum of 25 gallons, giving a total of 50 gallons of fuel.

### DRAINING FUEL VALVES AND LINES

The fuel strainer, located on the lower left side of the firewall, is provided with a quick drain which should be drained before the first flight of the day or after refueling, to check for fuel contamination. If contamination is found, fuel should be drained until the contamination stops. If contamination persists after draining fuel for a minute, contact a mechanic to check the fuel system.

Each fuel tank is provided with a fuel quick drain to check for contamination. Each tank should be checked for contamination in accordance with the above procedure.

### DRAINING FUEL SYSTEM

The bulk of the fuel may be drained from the fuel cells by the use of a siphon hose placed in the cell or tank through the filler neck. The remainder of the fuel may be drained by opening all the drain valves.

### CAUTION

Whenever the fuel system is completely drained and fuel is replenished it will be necessary to run the engine for a minimum of 3 minutes at 1000 RPM on each tank to ensure no air exists in the fuel supply lines.

## **TIRE INFLATION**

For maximum service from the tires, keep them inflated to the proper pressure of 30 psi for nose tire and 27 psi for main tires. Interchange the tires periodically for even wear. All wheels and tires are balanced before original installation, and the relationship of tire, tube and wheel should be maintained upon reinstallation. In the installation of new components, it may be necessary to rebalance the wheels with the tires mounted. Unbalanced wheels can cause extreme vibration in the landing gear.

## **BATTERY SERVICE**

Access to the 12-volt 25 ampere-hour battery is gained through the baggage compartment. It is located just aft of the baggage compartment. The battery container has a plastic drain tube which is normally closed off. This tube should be drained periodically to remove battery acid which may have collected in the tube.

The battery fluid level must not be brought above the baffle plates. It should be checked every 30 days to determine that the fluid level is proper and the connections are tight and free of corrosion.

If the battery is not properly charged, recharge it starting with a rate of four amperes and finishing with a rate of two amperes. The battery should be removed from the airplane for charging, and quick drains are not recommended.

The external power receptacle, if installed, is located on the right side of the fuselage aft of the baggage compartment.

Refer to the Arrow II Service Manual for battery servicing procedure.

## **WINTERIZATION**

For winter operation, a winterization kit is installed on the inlet opening of the oil cooler plenum chamber. This kit should be installed whenever the ambient temperature is 50°F or less. When the kit is not being used, it can be stowed on a bracket provided for this purpose on the outboard side of the oil cooler plenum chamber.

THIS PAGE INTENTIONALLY LEFT BLANK

---

## FACTS YOU SHOULD KNOW

The Federal Aviation Administration (FAA) occasionally publishes **Airworthiness Directives (AD's)** that apply to specific groups of aircraft. They are mandatory changes and are to be complied with within a time limit set by the FAA. When an AD is issued, it is sent by the FAA to the latest registered owner of the affected aircraft and also to subscribers of the service. The owners should periodically check with their Piper Service Center or Piper's Customer Services Department to see whether they have the latest AD against their airplane. The owner is solely responsible for keeping up with ADs.

Piper Aircraft Corporation takes a **continuing interest** in having owners get the most efficient use from their airplane and keeping it in the best mechanical condition. Consequently, Piper Aircraft, from time to time, issues service releases including Service Bulletins, Service Letters, Service Spares Letters, and others relating to the airplane.

**Piper Service Bulletins** are of special importance and Piper considers compliance mandatory. These are sent directly to the latest FAA-registered owners in the United States (U.S.) and Piper Service Centers worldwide. Depending on the nature of the release, material and labor allowances may apply. This information is provided to all authorized Piper Service Centers.

**Service Letters** deal with product improvements and servicing techniques pertaining to the airplane. They are sent to Piper Service Centers and, if necessary, to the latest FAA-registered owners in the U.S. Owners should give careful attention to Service Letter information.

**Service Spares Letters** offer improved parts, kits, and optional equipment which were not available originally, and which may be of interest to the owner.

Piper Aircraft Corporation offers a **subscription service** for Service Bulletins, Service Letters, and Service Spares Letters. This service is available to interested persons such as owners, pilots, and mechanics at a nominal fee, and may be obtained through an authorized Piper Service Center or Piper's Customer Services Department.

**Service manuals, parts catalogs**, and revisions to both, are available from Piper Service Centers or Piper's Customer Services Department. Any correspondence regarding the airplane should include the airplane model and serial number to ensure proper response.

**Pilot's Operating Manual** supplements are distributed by the manufacturer as necessary. These revisions and additions should be studied and put into the operating manual to keep it up to date. This manual contains important information about the operation of the aircraft and should be kept with the aircraft at all times, even after resale. Every owner, to avail himself of Piper Aircraft's support systems, should stay in close contact with an authorized Piper Service Center or Piper's Customer Services Department so that he can receive the latest information.

If the owner desires to have his aircraft modified, he must obtain FAA approval for the alteration. **Major alterations** accomplished in accordance with Advisory Circular 43.13-2, when performed by an A & P mechanic, may be approved by the local FAA office. Major alterations to the basic airframe or systems not covered by AC 43.13-2 require a Supplemental Type Certificate.

## ARROW II

---

The owner or pilot is required to ascertain that the following **Aircraft Papers** are in order and in the aircraft.

- a. To be displayed in the aircraft at all times:
  1. Aircraft Airworthiness Certificate Form FAA-1362B.
  2. Aircraft Registration Certificate Form FAA-500A.
  3. Aircraft Radio Station License Form FCC-404A, if transmitters are installed.
- b. To be carried on the aircraft at all times:
  1. Aircraft Flight Manual.
  2. Weight and Balance data plus a copy of the latest Repair and Alteration Form FAA-337, if applicable.
  3. Aircraft equipment list.

Although the aircraft and engine logbooks are not required to be in the aircraft, they should be made available upon request. Log books should be complete and up to date. Good records will reduce maintenance cost by giving the mechanic information about what has or has not been accomplished.

## PREVENTIVE MAINTENANCE

The holder of a pilot certificate issued under Federal Aviation Regulations (FAR) Part 61 may perform certain preventive maintenance as defined in the FARs. This maintenance may be performed only on an aircraft which the pilot owns and operates, and which is not used in air carrier or air taxi/commercial operations service

All other aircraft maintenance must be accomplished by a person or facility appropriately certificated by the Federal Aviation Administration (FAA) to perform that work.

Anytime maintenance is accomplished, an entry must be made in the appropriate aircraft maintenance records. The entry shall include:

- (a) The date the work was accomplished.
- (b) Description of the work.
- (c) Number of hours on the aircraft.
- (d) The certificate number of pilot performing the work.
- (e) Signature of the individual doing the work.

---

## REQUIRED SERVICE AND INSPECTION PERIODS

The Owner Service Agreement which the owner receives upon delivery of the aircraft should be kept in the aircraft at all times. This identifies him to authorized Piper dealers and entitles the owner to receive service in accordance with the regular service agreement terms. This agreement also entitles the transient owner full warranty by any Piper dealer in the world.

Piper Aircraft Corporation has developed inspection items and required inspection intervals for the PA-28 (see PA-28 Service and Inspection Manuals). The PA-28 Inspection Manual contains appropriate forms, and all inspection procedures should be complied with by a properly trained, knowledgeable, and qualified mechanic at a Piper Authorized Service Center or a reputable repair shop. Piper Aircraft Corporation cannot accept responsibility for the continued airworthiness of any aircraft not maintained to these standards, and/or not brought into compliance with applicable Service Bulletins issued by Piper Aircraft Corporation, instructions issued by the engine, propeller, or accessory manufacturers, or Airworthiness Directives issued by the FAA.

A Progressive Inspection, approved by the Federal Aviation Administration (FAA), is also available to the owner. This involves routine and detailed inspections to allow maximum utilization of the airplane. Maintenance inspection costs are reduced, and the maximum standard of continued airworthiness is maintained. Complete details are available from Piper Aircraft Corporation.

In addition, but in conjunction with the above, the FAA requires periodic inspections on all aircraft to keep the Airworthiness Certificate in effect. The owner is responsible for assuring compliance with these inspection requirements and for maintaining proper documentation in logbooks and/or maintenance records.

A spectrographic analysis of the engine oil is available from several sources. This inspection, if performed properly, provides a good check of the internal condition of the engine. To be accurate, induction air filters must be cleaned or changed regularly, and oil samples must be taken and sent in at regular intervals.

**SPECIAL INSTRUCTIONS (cont)**

8. RECOMMENDED FOR USE WHEN OPERATING AT TEMPERATURES BELOW 20°F.
  9. "O" RING, CONTROL SHAFT BUSHING - DISASSEMBLE "O" RING RETAINER PLATES FROM INSTRUMENT PANEL. LUBRICATE "O" RING AND REASSEMBLE.
  10. GREASE HOLES REQUIRE A NEEDLE TYPE ADAPTER ON THE GREASE GUN NOZZLE.
  11. AILERON HINGES WITH TEFLON SLEEVES SHOULD NOT BE LUBRICATED. AILERON HINGES WITHOUT TEFLON SLEEVES SHOULD FIRST BE CLEANED WITH A DRY TYPE SOLVENT THEN LUBRICATED WITH MIL-L-7870 LUBRICATING OIL.
- NOTES**
1. PILOT AND PASSENGER SEATS - LUBRICATE TRACK ROLLERS AND STOP PINS AS REQUIRED. (TYPE OF LUBRICANT: 'A')
  2. WHEEL BEARINGS REQUIRE CLEANING AND REPACKING AFTER EXPOSURE TO AN ABNORMAL QUANTITY OF WATER.
  3. FUEL SELECTOR VALVE - LUBRICATE SELECTOR VALVE AS REQUIRED, REFER TO PIPER SERVICE LETTER NO. 351
  4. SEE LYCOMING SERVICE INSTRUCTIONS NO. 1014 FOR USE OF DETERGENT OIL.
  5. ON AIRCRAFT EQUIPPED WITH BACKUP GEAR EXTENDER.

**CAUTIONS**

1. DO NOT USE HYDRAULIC FLUID WITH A CASTOR OIL OR ESTER BASE.
2. NO NOT OVER-LUBRICATE COCKPIT CONTROLS.
3. DO NOT APPLY LUBRICANT TO RUBBER PARTS.

**EXAMPLE**

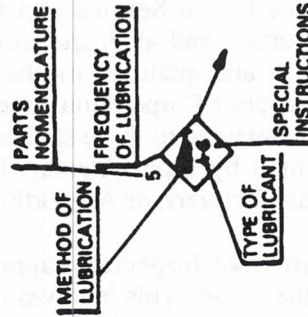

**TYPE OF LUBRICANT**

IDENTIFICATION LETTER	LUBRICANT	SPECIFICATION	PREFERRED PRODUCT AND VENDOR
A	LUBRICATING OIL, GENERAL PURPOSE, LOW TEMP	MIL-L-7870	
B	LUBRICATING OIL, AIRCRAFT RECIPROCATING ENGINE (PISTON) GRADE AS SPECIFIED SAE 50 ABOVE 60°F AIR TEMP. SAE 40 30°F TO 90°F AIR TEMP. SAE 30 0° to 70°F AIR TEMP. SAE 20 BELOW 10°F AIR TEMP.	MIL-L-6082	
C	HYDRAULIC FLUID	MIL-H-5606	
D	PETROLEUM BASE GREASE, AIRCRAFT AND INSTRUMENT, GEAR AND ACTUATOR SCREW GREASE, AIRCRAFT, HIGH TEMP.	MIL-G-23827	TEXACO MARFAK ALL PURPOSE GREASE, MOBIL GREASE 77 (OR MOBILUX EP2), SHELL ALVANIA EP GREASE 2
F	COMPOUND, SILICONE, SOFT FILM	MIL-C-21567	FISKE BROS. REFINING CO.
G	PARKER "O" RING LUBRICANT		
H	AERO LUBRIPLATE		
I	FLUOROCARBON RELEASE AGENT DRY LUBRICANT	MS-122	
J	GREASE - LUBRICANT GEN PURPOSE AIRCRAFT	MIL-G-7711	

**SPECIAL INSTRUCTIONS**

1. AIR FILTER - TO CLEAN FILTER, TAP GENTLY TO REMOVE DIRT PARTICLES. DO NOT BLOW OUT WITH COMPRESSED AIR OR USE OIL. REPLACE FILTER IF PUNCTURED OR DAMAGED.
2. BEARINGS AND BUSHINGS - CLEAN EXTERIOR WITH A DRY TYPE SOLVENT BEFORE LUBRICATING.
3. WHEEL BEARINGS - DISASSEMBLE AND CLEAN WITH A DRY TYPE SOLVENT. ASCERTAIN THAT GREASE IS PACKED BETWEEN THE BEARING ROLLER AND CONE. DO NOT PACK GREASE IN WHEEL HOUSING.
4. OLEO STRUTS, HYDRAULIC PUMP RESERVOIR AND BRAKE RESERVOIR - FILL PER INSTRUCTIONS ON UNIT OR CONTAINER, OR REFER TO SERVICE MANUAL, SECTION II
5. PROPELLER - REMOVE ONE OF THE TWO GREASE FITTINGS FOR EACH BLADE. APPLY GREASE THROUGH FITTING UNTIL FRESH GREASE APPEARS AT HOLE OF REMOVED FITTING.
6. LUBRICATION POINTS - WIPE ALL LUBRICATION POINTS CLEAN OF OLD GREASE, OIL, DIRT, ETC. BEFORE LUBRICATING.
7. INTERVALS BETWEEN OIL CHANGES CAN BE INCREASED AS MUCH AS 100% ON ENGINES EQUIPPED WITH FULL FLOW (CARTRIDGE TYPE) OIL FILTERS, PROVIDED THE ELEMENT IS REPLACED EACH 50 HOURS OF OPERATION.

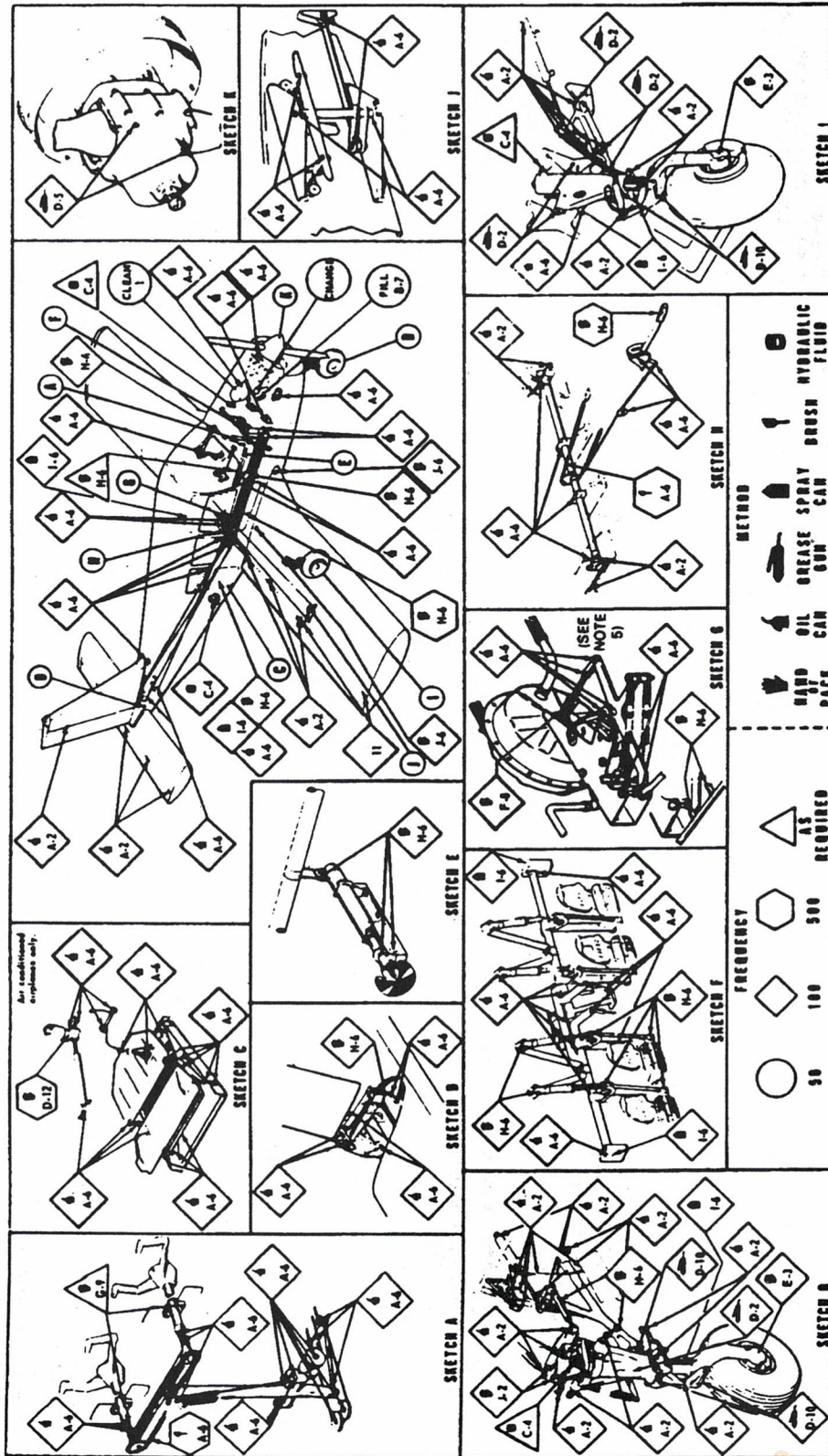

Lubrication Chart

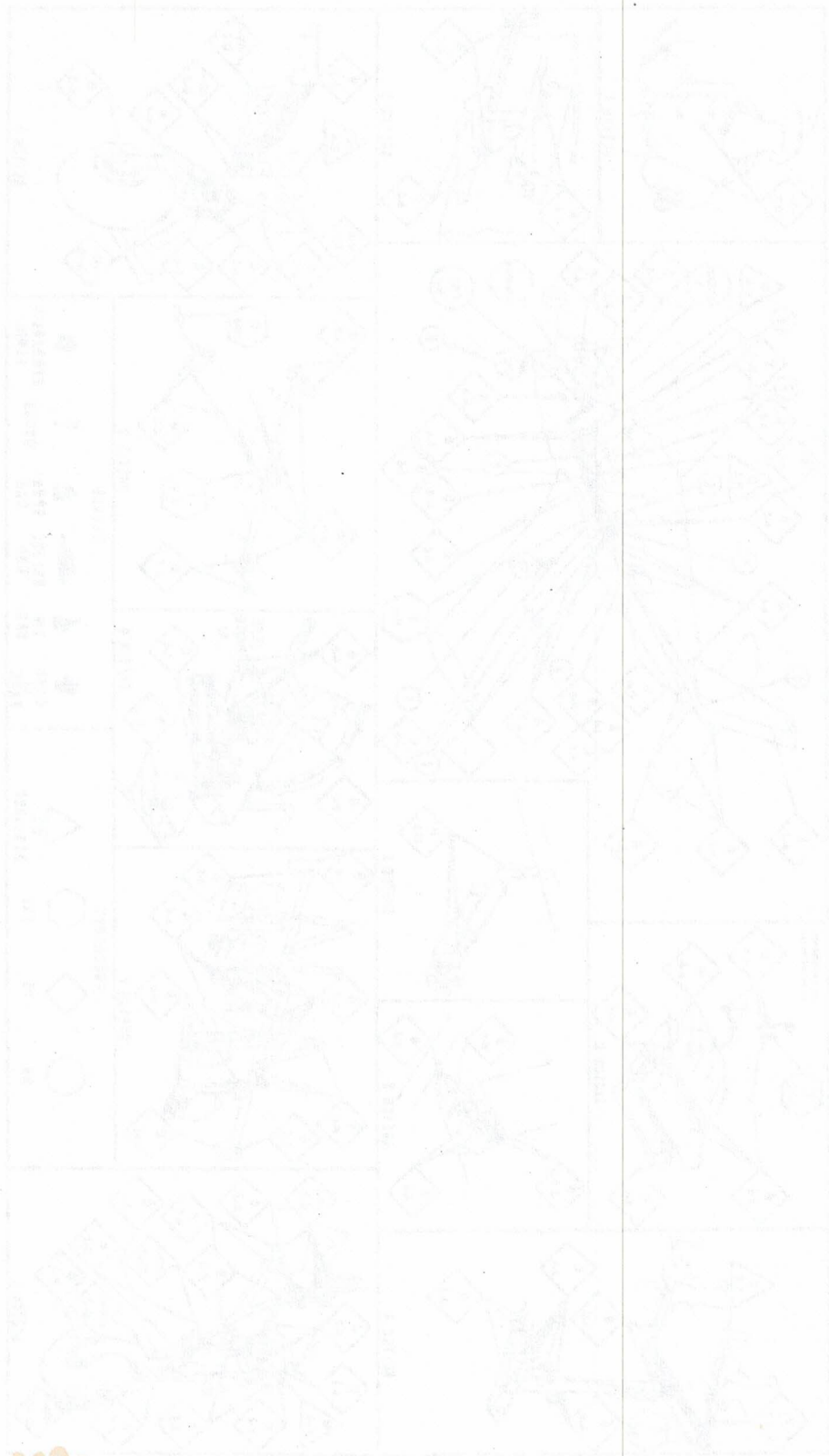

1170354





